

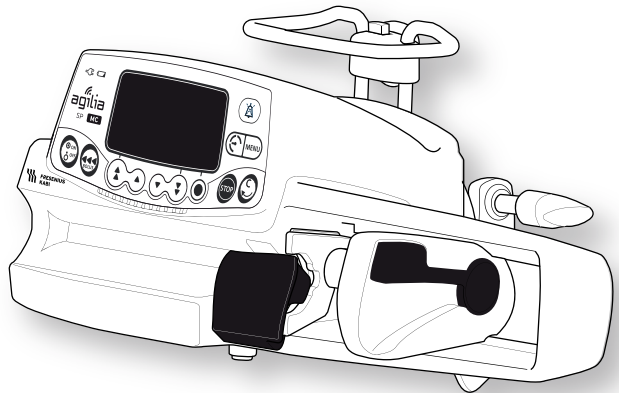

Agilia SP MC **Agilia SP MC WiFi** Syringe Infusion Pumps

Applicable to software version 2.2



INSTRUCTIONS FOR USE

For use in healthcare facilities



**FRESENIUS
KABI**

caring for life

Symbol Descriptions



Warning
(Refer to the Instructions for Use)



Name and address of the manufacturer / Date of manufacture



Refer to the Instructions for Use



Name and address of the manufacturing facility



Product reference / part number



Protection against electric shock: class II



Product serial number



Non-ionizing electromagnetic radiation



Input terminal - connector



Fragile, handle with care



Output terminal - connector



This way up



Electrical fuses



Keep away from rain



Alternating Current (AC)



Temperature limitation



Direct Current (DC)



Humidity limitation

IP22

Index of protection against solid foreign objects (> 12.5 mm) and dripping liquids



Atmospheric pressure limitation



Not for use in residential areas



General symbol for recyclable material



Part included in a recycling process



Eco packaging symbol



Protection against leakage current; defibrillation-proof type CF applied part



CE mark



Warning of a **potential hazard** that could result in **serious** personal **injury** and/or product damage if the written instructions are not followed.



Recommendations to be followed.

Table of Contents

1	INTRODUCTION	9
1.1	SCOPE	9
1.2	INTENDED USE.....	9
1.3	PRINCIPLES OF OPERATION.....	10
1.4	INTENDED PRODUCTS TO BE INFUSED.....	10
1.5	INTENDED USERS.....	11
1.6	INTENDED PATIENTS	11
1.7	CONTRAINDICATIONS.....	12
1.8	USE ENVIRONMENT.....	13
2	AGILIA CONNECT INFUSION SYSTEM	14
3	DESCRIPTION	15
3.1	FRONT VIEW.....	15
3.2	BOTTOM VIEW (DEVICE IDENTIFICATION LABEL)	15
3.3	BACK VIEW.....	16
3.4	KEYPAD.....	17
3.5	DISPLAY AND SYMBOLS.....	19
3.5.1	<i>Infusion Status</i>	19
3.5.2	<i>Screen Options</i>	19
3.5.3	<i>Navigation Buttons</i>	20
3.5.4	<i>Alarms and Safety Features</i>	20
3.5.5	<i>Infusion Features</i>	20
3.5.6	<i>Data Communication</i>	20
3.6	PACKAGING	21
4	FUNDAMENTALS	22
4.1	PROFILES	22
4.2	DRUG LIBRARIES.....	23
4.3	DRUG LISTS.....	24
4.4	DRUGS	24
4.4.1	<i>Infusion Rates</i>	24
4.4.2	<i>Drug X (mL/h)</i>	24
4.4.3	<i>Hard Limits and Soft Limits</i>	24

4.4.4	Infusion Modes	25
4.5	DATA SET	25
5	INSTALLATION	26
5.1	TYPES OF INSTALLATIONS	26
5.2	USING THE ROTATING POLE CLAMP	27
5.3	ATTACHING THE PUMP(S)	29
5.3.1	Attaching to a Pole	29
5.3.2	Attaching to a Rail	29
5.3.3	Using on a Flat Table	30
5.3.4	Attaching Two Pumps Together	30
6	GETTING STARTED	31
6.1	FLOWCHART	31
6.2	USING THE PUMP FOR THE FIRST TIME	32
6.3	POWERING ON	32
6.4	INSTALLING A SYRINGE	34
6.5	PUMP HEIGHT	35
7	OPERATION	36
7.1	FLOWCHART	36
7.2	SELECTING A PROFILE	37
7.3	SELECTING THE INFUSION RATE (FLOW RATE OR DOSE)	38
7.4	SELECTING A SYRINGE	39
7.5	SELECTING A DRUG	40
7.6	PROGRAMMING AN INFUSION	41
7.6.1	Programming an Infusion by Flow Rate	41
7.6.2	Programming an Infusion by Dose	41
7.6.3	Programming Beyond Soft Limits	47
7.7	STARTING AN INFUSION	49
7.8	MONITORING AN INFUSION	50
7.9	FUNCTIONS DURING INFUSION	52
7.9.1	Stop	52
7.9.2	Rate Titration	52
7.9.3	Administering a Bolus	53
7.10	COMPLETING AN INFUSION	57
7.10.1	Near End of Infusion Alert	57

7.10.2	<i>End of Infusion</i>	58
7.10.3	<i>Powering off</i>	58
7.11	INFUSION MODES	59
7.11.1	<i>Simple Rate</i>	59
7.11.2	<i>Volume/Time & Dose/Time</i>	59
7.11.3	<i>Volume Limit</i>	60
7.12	OTHER FUNCTIONS	62
7.12.1	<i>Priming the Syringe and the Extension Set</i>	62
7.12.2	<i>Pre-programming the Pump</i>	64

8 MENUS 65

8.1	OVERVIEW	65
8.2	PROFILE	66
8.3	PRESSURE.....	67
8.4	KEYPAD LOCK STATUS.....	70
8.5	BATTERY LIFE.....	72
8.6	VOLUME INFUSED / DOSE INFUSED	73
8.7	PAUSE.....	74
8.8	PROGRAMMED BOLUS	75
8.9	PATIENT	75
8.10	DAY/NIGHT MODE	76
8.11	VOLUME/TIME & DOSE/TIME.....	78
8.12	VOLUME LIMIT.....	78
8.13	ALARM VOLUME	79
8.14	VOLUME-DOSE HISTORY	80
8.15	VIEW FLOW RATE HISTORY	81
8.16	VIEW PRESSURE HISTORY	82
8.17	SYRINGE.....	83
8.18	VIEW EVENT LOG.....	84
8.19	DATE / TIME	85
8.20	MAINTENANCE	86
8.21	LIBRARY INFORMATION	87
8.22	CLINICAL INFORMATION	88
8.23	DATA SET.....	89

9	OPTIONS	90
9.1	COMMANDS	90
9.2	OPTION DESCRIPTIONS	90
9.3	PUMP SETTINGS	91
10	DATA COMMUNICATION	92
10.1	OVERVIEW	92
10.2	COMMUNICATION VIA AGILIA CABLES	92
10.3	COMMUNICATION VIA WI-FI	93
10.4	DATA SET UPLOAD	94
11	USER TEST	95
12	ALARMS AND SAFETY FEATURES	96
12.1	INTRODUCTION.....	96
12.2	ALARM DESCRIPTIONS	96
12.3	GENERAL REMARKS.....	97
12.4	LIST OF ALARMS	97
13	SYRINGES	103
13.1	SYRINGE LIST	103
13.2	PREPARING A SYRINGE	104
13.3	OPERATIONS FOR SYRINGES	106
13.4	GRAVITY INFUSION IN PARALLEL WITH A PUMP	107
14	DEVICE STORAGE	108
14.1	PRECAUTIONS FOR STORAGE	108
14.2	STORAGE AND TRANSPORT CONDITIONS.....	108
14.3	PREPARING THE DEVICE FOR STORAGE	109
14.4	USING THE DEVICE AFTER STORAGE	109
15	SPECIFICATIONS	110
15.1	ESSENTIAL FEATURES.....	110
15.2	FLOW RATE	111

15.3	VOLUME TO BE INFUSED (VTBI)	111
15.4	DOSE TO BE INFUSED (DTBI)	112
15.5	INFUSION TIME.....	112
15.6	CONCENTRATION	112
15.7	PATIENT DATA	113
15.8	PRESSURE MANAGEMENT	113
15.9	ACCURACY	114
15.10	UNITS AND CONVERSION RULES.....	116
16	CLEANING AND DISINFECTING	118
16.1	WHEN TO CLEAN AND DISINFECT THE PUMP	118
16.2	RECOMMENDED AND PROHIBITED AGENTS.....	119
16.3	INSTRUCTIONS FOR CLEANING AND DISINFECTING	119
17	POWER MANAGEMENT	122
17.1	AC POWER SUPPLY PRECAUTIONS.....	122
17.2	BATTERY PRECAUTIONS.....	122
17.3	BATTERY OPERATING MODE	123
18	TECHNICAL CHARACTERISTICS	124
18.1	POWER SUPPLY.....	124
18.2	BATTERY	124
18.3	POWER CONSUMPTION.....	124
18.4	COMMUNICATION PORT	125
18.5	INFRARED COMMUNICATION.....	125
18.6	SOUND LEVELS.....	126
18.7	COMPLIANCE	126
18.8	DIMENSIONS AND WEIGHT	127
18.9	TRUMPET AND START-UP CURVES.....	127
19	WI-FI	130
19.1	GENERAL INFORMATION	130
19.2	SPECIFICATIONS	131

20 TROUBLESHOOTING	133
<hr/>	
21 RECYCLING	135
<hr/>	
22 WARRANTY	136
<hr/>	
22.1 GENERAL WARRANTY CONDITIONS	136
22.2 LIMITED WARRANTY	136
22.3 WARRANTY CONDITIONS FOR ACCESSORIES	136
23 GUIDANCE AND MANUFACTURER'S DECLARATION ON EMC	137
<hr/>	
23.1 ELECTROMAGNETIC COMPATIBILITY	137
23.2 ELECTROSTATIC DISCHARGE (ESD)	138
23.3 ELECTROMAGNETIC COMPATIBILITY AND INTERFERENCE GUIDANCE	138
23.4 EMC AND ESSENTIAL PERFORMANCES	140
24 SERVICING	147
<hr/>	
24.1 INFORMATION ON DEVICE SERVICING	147
24.2 MAINTENANCE REQUIREMENTS	147
24.3 QUALITY CONTROL	148
25 GLOSSARY OF TERMS	149
<hr/>	
APPENDIX: FACTORY CONFIGURATION	153
<hr/>	
INDEX	154
<hr/>	

1 Introduction

1.1 Scope

These Instructions for Use (IFU) are applicable to the Agilia SP MC and Agilia SP MC WiFi pumps. These devices are referred to throughout this manual as the "Agilia SP MC".

The user must adhere to the instructions specified in this IFU. Failure to adhere to these instructions may result in damage to the equipment, injury to patients or injury to users.

Warning

Check that this IFU is applicable to the current software version of the device.



- *The software version of the device is displayed on the start-up screen.*
- *The software version described in this IFU is displayed in the Release Notes, page 156.*

1.2 Intended Use

The Agilia SP MC Syringe Pump is intended for use on adults, pediatrics, and neonatal patients for the intermittent or continuous delivery of parenteral fluids (such as solutions, colloids, parenteral nutrition), medications (such as diluted drugs, chemotherapy, anesthesia drugs), blood and blood derivatives, and medications through clinically accepted routes of administration. It is intended for use by trained healthcare professionals in clinical healthcare facilities and in pre-hospital medical ground transportation.

1.3 Principles of Operation

Agilia SP MC is a programmable electronic medical system dedicated to administering a pre-determined volume of a syringe at a programmed rate. This syringe pump ensures a fluid delivery, by pushing the syringe plunger and advancing the liquid to the patient through an extension set (applied part).

Agilia SP MC is a transportable and reusable device that can be used everyday.

The size of a syringe can be 5, 10, 20, 30 or 50-60 mL.

Agilia SP MC can be used for intermittent or continuous infusions.

Agilia SP MC is intended for use on only one patient at a time. It can be reused indefinitely on multiple patients throughout its lifetime.

1.4 Intended Products to be Infused

The pump administers products through clinically accepted routes. These products include but are not limited to the following:

	Intended Products
Parenteral Fluids	<ul style="list-style-type: none">▪ Standard solutions▪ Colloids▪ Parenteral nutrition
Medication	<ul style="list-style-type: none">▪ Diluted drugs▪ Antibiotics▪ Chemotherapy▪ Catecholamines▪ Short acting drugs▪ Anesthesia drugs
Transfusion	<ul style="list-style-type: none">▪ Blood▪ Red blood cells▪ Platelets▪ Plasma▪ Albumin

When using Agilia SP MC to infuse critical medications, ensure that adequate monitoring is provided, and that backup pumps and syringes are available for immediate use.

Only use Agilia SP MC for the infusion of fluids that are intended for infusion pumps.

Administration Routes

The system allows infusion via the following access routes:

- IV access with any device that administers a medical fluid to a vein and is equipped with a female Luer lock,
- Subcutaneous access.

1.5 Intended Users

The pump must only be used by qualified and trained healthcare professionals including but not limited to: nurses (primary users), physicians, nurse practitioners and physician assistants.

Typical initial training duration: 1 hour.

It is recommended that users attend a refresher training session of about 20 minutes every year.

For training, contact your **Fresenius Kabi** sales representative.

1.6 Intended Patients

Agilia SP MC is intended to be used according to healthcare facilities protocols on patients with the following characteristics:

	Patient Characteristics
Sex	Male Female
Age	Neonates Pediatrics Adults Elderly
Weight	0.25 kg to 350 kg
Body Surface Area	0.05 m ² to 4.5 m ²

When using the pump with a very sensitive population such as the neonates, make sure to:

- Switch to night mode
- Set the alarm volume to the minimum level

Warning



Specific attention for infusing high risk and life sustaining medication therapies : use the smallest compatible syringe size necessary to deliver the fluid or medication; this is especially important when infusing high risk or life-sustaining medications at low infusion rates (e.g., less than 5 mL per hour, and especially flow rates less than 0.5 mL per hour). Using a larger syringe when infusing at low rates can lead to inadequate syringe pump performance including delivery inaccuracies, delay of therapy, and delayed generation of occlusion alarms. This is due to the increased friction and compliance of the syringe plunger head with larger syringes.

1.7 Contraindications

- Do not modify the pump (except in the case of operations recommended by **Fresenius Kabi**).
- Do not use the pump with the following **fluids**:
 - Flammable liquids
 - Fluids not suitable for infusion
- Do not use the pump in the following **environments**:
 - Explosive or flammable environments
 - High humidity environments (shower, bath, etc.)
 - Ultrasonic environments
 - Magnetic Resonance Imaging (MRI)
 - Hyperbaric chamber
- Do not use the pump for the following **purposes**:
 - Infusion in association with a dialyser or ECMO
 - Enteral nutrition
 - Epidural use
- Do not allow the pump to come in direct contact with the patient's body.
- While the pump is infusing a patient, do not connect a computer installed with Agilia Partner software to perform technical operations.

1.8 Use Environment

Agilia SP MC is intended for use in healthcare facilities, under the supervision of trained healthcare personnel.

The pump must be used in the following operational conditions to ensure proper performance:

- Operating temperature range:
5 °C to 40 °C
- Operating pressure range:
700 hPa (525 mmHg / 10.15 PSI) to 1060 hPa (795 mmHg / 15.37 PSI)
- Operating humidity range:
20 % to 90 % with no condensation
- Altitude:
Up to 3000 m above sea-level



Warning

The functionality of the pump can be affected by pressure variations, mechanical shocks, heat ignition sources, and so on.



Information

- *The pump can be used in ambulances exclusively with the Agilia Holder Ambulance accessory. Due to use in road ambulances, performances of the device can be modified. For more information, refer to Agilia Holder Ambulance IFU.*
- *For more information on using the device in specific conditions, contact your **Fresenius Kabi** representative.*

2 Agilia Connect Infusion System

Agilia Range		Description
Pump	Agilia VP range	Volumetric Infusion Pump Pumps designed to deliver the contents of parenteral infusion container (bag or bottle) through a line connected to a patient.
	Agilia SP range	Syringe Infusion Pump Pumps designed to deliver the contents of a syringe through a line connected to a patient.
Software	Agilia Vigilant Drug'Lib	Medication Safety Software Software designed to create, customize and manage data sets to be uploaded to the Agilia VP and SP infusion pumps.
	Agilia Partner	Maintenance Software Software designed to maintain, configure, test and calibrate the Agilia VP and SP infusion pumps.
	Centerium	Distribution Server Software intended to distribute data sets to Agilia infusion pumps and centralize information coming from infusion pumps for post analysis and reporting.
	Vigilant Insight	Infusion Data Reporting Software Software designed to improve the accuracy of clinical settings included into a data set. It provides reports about the use of infusion pumps.
Rack	Link Agilia Link+ Agilia	Stacking Rack Systems Rack systems designed to stack 4, 6 or 8 Agilia infusion pumps. Link Agilia is designed to centralize the power supply. Link+ Agilia is designed to centralize the power supply and to centrally replicate infusion pump signalling.
Accessories	Agilia Holder Ambulance	Medical device intended to be used in road ambulances equipped with AC power source and a horizontal rail in order to fix an infusion pump.
Disposables	Syringes (applied part)	See section 13, page 103.



Information

For a list of compatible accessories, disposables and software, and for ordering information, refer to the System Components booklet.

3 Description

3.1 Front View

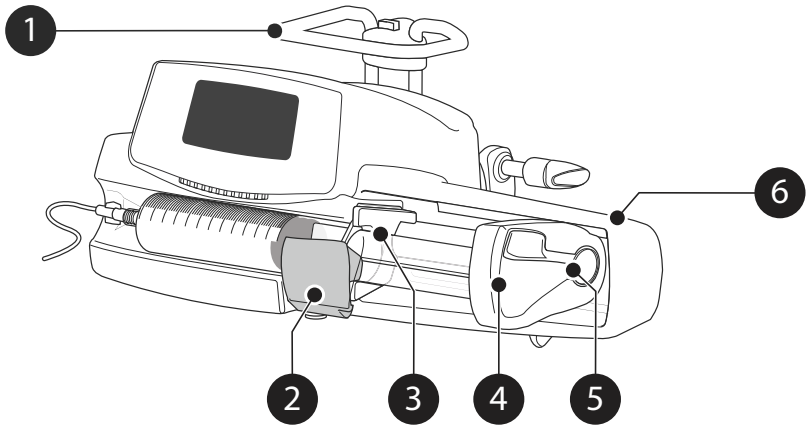
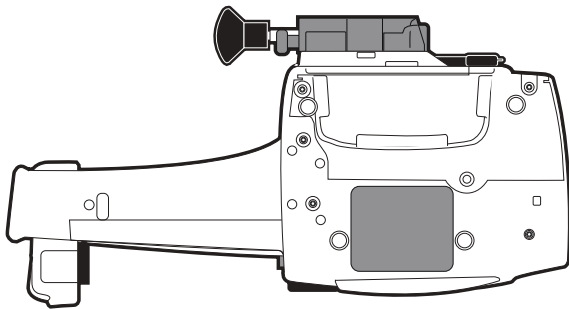

Figure 3.1: Front View

Legend

- | | | | |
|---|-----------------------|---|---------------------|
| 1 | Handle | 4 | Plunger Driver |
| 2 | Syringe Barrel Clasp | 5 | Disengagement Lever |
| 3 | Syringe Flange Cradle | 6 | Syringe Guard |
-

3.2 Bottom View (Device Identification Label)



For more information on device identification label symbols, see Symbol Descriptions, page 2.

3.3 Back View

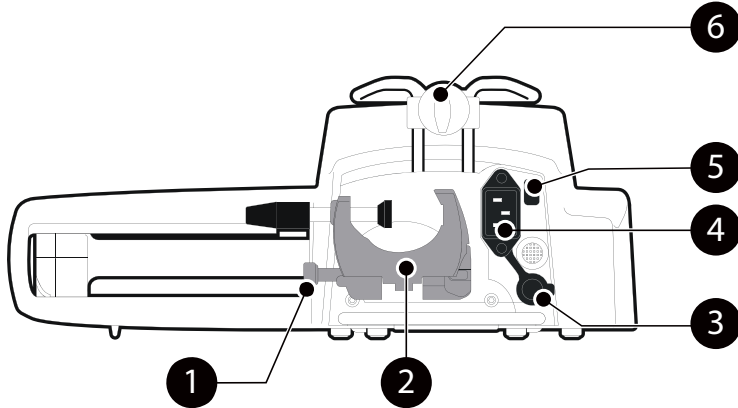





Figure 3.2: Back View

Legend

- | | | | |
|---|--------------------------|---|----------------------|
| 1 | Release Button | 4 | Power Cord Inlet |
| 2 | Rotating Pole Clamp | 5 | Infrared Cell |
| 3 | RS232 Communication Port | 6 | Attachment Lock Knob |

Symbol	Location	Description
 	Near Power Cord Inlet	Warning See section 18, page 124.
	Near RS232 Communication Port	Warning See section 10, page 92.

3.4 Keypad

3.4.1 Keypad Description

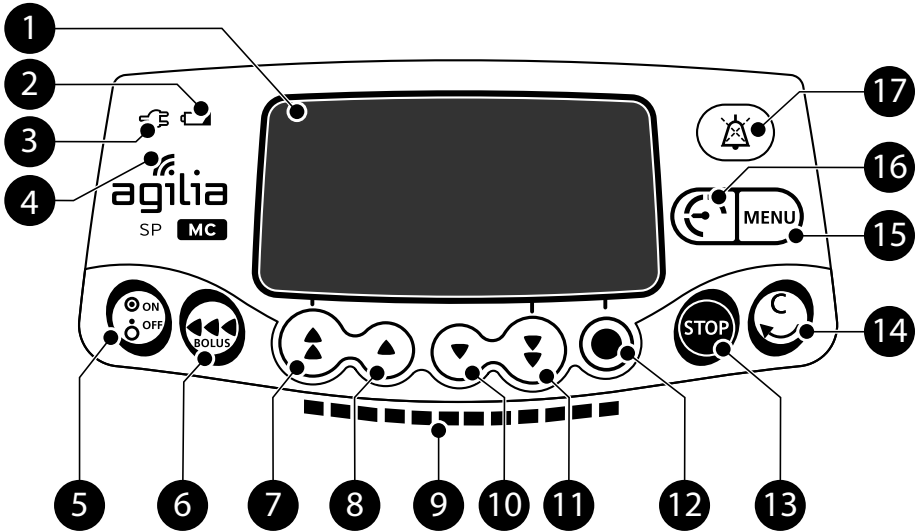







Figure 3.3: Keypad

Legend

1	Screen	10	Decrement
2	Battery Charge Status Indicator	11	Fast Decrement
3	Power Supply Indicator	12	Confirm Value / Move to Next Field
4	Wi-Fi Symbol	13	Stop
5	On / Off	14	Cancel Value / Move Back to Previous Field
6	Bolus / Prime	15	Menu
7	Fast Increment	16	Pressure Menu
8	Increment	17	Alarm Silence
9	Infusion Indicator Lights		

3.4.2 Keypad Details





3.4.2.1 Selection Keys

Key	Description
 	Arrow Keys Keys for selecting volume, time, flow rate and other values.
 + 	Fast Access to Maximum Value or Top of a List
 + 	Fast Access to Minimum Value or Bottom of a List

Note:

- Pressing and holding any of the arrow keys results in faster increment or decrement.



3.4.2.2 Infusion Indicator Lights

Indicator	Description
	Infusion in Progress (flashing green)
	Low-Priority Alarm (constant yellow)
	Medium-Priority Alarm (flashing yellow)
	High-Priority Alarm (flashing red)

Note:



- Infusion indicator lights provide information about the infusion: in progress, or with a low, medium or high-priority alarm.
- Green indicator lights will continuously flash from right to left while the infusion is running.
- The frequency of flashing varies according to flow rate.

3.4.2.3 Status Indicators





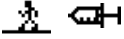







Indicator	Description
	Power Supply Indicator When the device is attached to an active power supply, the indicator light is a constant green. If the pump is not connected to the AC power, it does not light up.
	Battery Charge Status Indicator When the device is attached to an active power supply, the indicator light provides information about battery charge status: <ul style="list-style-type: none"> If the indicator is blinking, the battery is being charged. If the indicator is lit permanently, the battery is fully charged. If the pump is not connected to the AC power, it does not light up.

3.5 Display and Symbols











3.5.1 Infusion Status

Symbol	Description
	Infusion in Progress (Basic Profile + Custom Profiles with a drug list) Symbols for infusion in progress.
	Infusion in Progress (Custom Profiles with a drug library) This symbol is displayed when the pump is infusing a drug customized with Agilia Vigilant Drug'Lib software.
	Infusion Stopped STOP remains in the center of the screen until the user starts the infusion again.



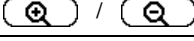

3.5.2 Screen Options

Symbol	Description
	Battery Logo <ul style="list-style-type: none"> ▪ This symbol shows three different charge levels. <ul style="list-style-type: none">  < 30 % battery charge  30 % - 70 % battery charge  > 70 % battery charge ▪ If the 'Battery logo' option is enabled, this symbol is displayed constantly. ▪ If the 'Battery logo' option is disabled, this symbol is only displayed when the pump is operating on battery.
	Pressure Logo This symbol gives information about pump pressure settings and measured pressure levels.
	Keypad locked symbol This symbol informs the user that the keypad is locked.
	Wi-Fi module status <ul style="list-style-type: none"> ▪  The Wi-Fi signal strength is high. ▪  The Wi-Fi signal strength is medium. ▪  The Wi-Fi signal strength is low. ▪  No Wi-Fi signal (the Wi-Fi module is activated). ▪  The Wi-Fi module is not activated.

3.5.3 Navigation Buttons

Symbol	Description
	Start
	Confirm
	Access Function
	Access Function and Clear Settings
	Exit Function
	Change Selection
	Program Function
	Select / Unselect
	See More Information
	Zoom in / Zoom out
	Move the Event Marker to the Left / Right

3.5.4 Alarms and Safety Features

Symbol	Description
	Power Disconnection
	Alarm Silenced
	Pressure Increase
	Drop in Pressure

Note: For more information on alarms, see section 12, page 96.

3.5.5 Infusion Features

Symbol	Description
	Loading Dose This symbol is displayed when programming a loading dose.

3.5.6 Data Communication

Symbol	Description
	Data Set Loaded A new data set has been loaded to the pump.

3.6 Packaging

The Agilia SP MC packaging contains the following:

- 1 Agilia SP MC pump
- 1 Instructions for Use manual
(this document + System Components booklet)
- 1 Power cord

Packaging weight: Approximately 530 g.

Packaging consists of: Recycled cardboard, expanded foam.

Information



- *It is the healthcare facility's responsibility to check the pump integrity upon reception.*
- *If the packaging contents are incomplete or damaged, contact your **Fresenius Kabi** sales representative.*

4 Fundamentals

4.1 Profiles

A **profile** defines the device configuration and drug library used for a group of patients in a given health care environment.

By default, factory settings include only 1 profile (Basic Profile).

Custom profiles can be created and loaded to the pump with Agilia Vigilant Drug'Lib software. Custom profiles feature a specific pump configuration and a drug library.

A pump can manage up to 20 profiles:

- 1 Basic Profile
- Up to 19 custom profiles

Information



For pumps used on only one group of patients, we recommend disabling the ability to select the profile, thus locking the pumps to the selected profile.

4.1.1 Basic Profile

Basic Profile allows programming of an infusion whose settings have not been pre-defined with Agilia Vigilant Drug'Lib software.

To program an infusion with Basic Profile, choose "Basic Profile" when selecting a profile.

Basic Profile has the following characteristics:

- All infusion settings are to be defined.
- The Agilia Vigilant Drug'Lib software's safeguards are unavailable:
 - The infusion is programmed without drug names.
 - Limits on drug infusion rates are not included.

Configurations and settings accessible in Basic Profile may not be suitable for all patient groups and protocols.

4.1.2 Custom Profiles

Custom profiles can be configured and loaded to the pump with Agilia Vigilant Drug'Lib software.

A custom profile contains the following:

- a **specific device configuration** (pump settings that control the mechanical functions of the pump such as alarm volume, and so on)
- a comprehensive list of medications and fluids to be infused (optional):
 - a **drug library**: a list with limits on drug infusion rates, see section 4.2, page 23.
 - a **drug list**: a list without limits on drug infusion rates.

Depending on the way it is pre-configured with Agilia Vigilant Drug'Lib software, a custom profile may or may not include all of the functionalities described in this IFU.

Information



- *We recommend using a custom profile when infusing critical drugs.*
- *We recommend that you create and upload profiles in order to limit usage errors, and to better adapt the use of the pump to the local practices of the different care units. For example, make sure to limit flow rates for sensitive populations.*
- *We recommend creating a specific profile per patient population and/or care unit, therapy, protocol, and so on.*

4.2 Drug Libraries

A drug library is a comprehensive list of drugs that includes limits on drug infusion rates.

Information



- *Each drug library can support up to 150 drug entries that are defined and validated by healthcare professionals according to the drug protocols used at the healthcare facility and/or ward level.*
- *Drug settings may be adjusted on the pump according to pre-defined programming limits, such as dose limits.*
- *Infusion modes are not adjustable on the pump for drugs pre-configured with Agilia Vigilant Drug'Lib software.*

4.3 Drug Lists

A drug list is a list of drugs that does not include limits on drug infusion rates.

4.4 Drugs

4.4.1 Infusion Rates

A drug can be pre-configured with Agilia Vigilant Drug'Lib software according to one of the following rates:

- **Flow rate:** Infusion of a volume over a period of time
- **Dose:** Infusion of a specific amount of a drug corresponding to a dose rate

4.4.2 Drug X (mL/h)

Drug X (mL/h) is an open entry that can be selected if the intended drug is not found in the drug library. It has the following characteristics:

- Fewer limits than the other drugs in the library.
- A full compliment of the Agilia Vigilant Drug'Lib software's safeguards are unavailable.

It is strongly recommended to use Drug X (mL/h) in a limited number of clinical cases and under close patient monitoring by the clinical staff.

For each custom profile, the healthcare facility can enable or disable Drug X (mL/h) using the Agilia Vigilant Drug'Lib software.

4.4.3 Hard Limits and Soft Limits

Programming limits can be set for each drug with Agilia Vigilant Drug'Lib software. Two types of limits can be set:

- **Hard limits:** limits that cannot be overridden when programming an infusion.
- **Soft limits:** limits that can be overridden within an authorized range when programming an infusion. An additional confirmation will be required.

4.4.4 Infusion Modes

An infusion can be started according to the following modes:

Infusion Mode	Description	Infusion Rate	
		Flow Rate	Dose
Simple Rate	Infusion with a programmed rate	✓	✓
Volume/Time Dose/Time	Infusion of a programmed volume or dose over a programmed period of time	✓	✓
Volume Limit	Infusion with a limitation on the volume or dose to be infused	✓	✓

4.5 Data Set

A **data set** is a combination of custom profiles (up to a maximum of 19) that can be uploaded to Agilia pumps with Agilia Vigilant Drug'Lib software.

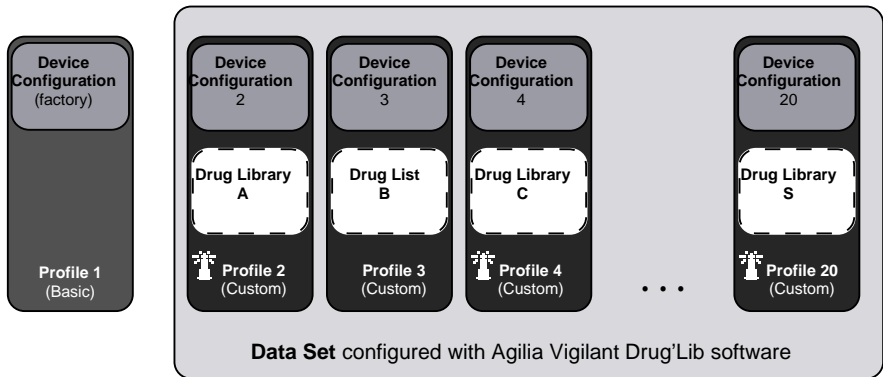

If there is no data set uploaded to the pump, the pump can be used with the Basic Profile, without the protections of the Agilia Vigilant Drug'Lib software.

5 Installation

5.1 Types of Installations

A pump can be installed on any of the following:

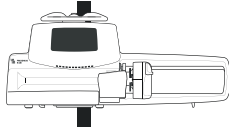
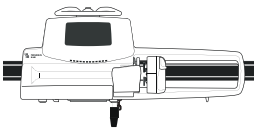
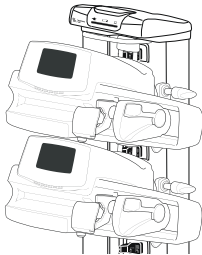
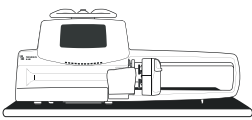
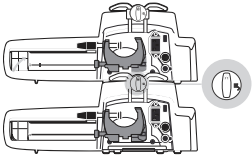
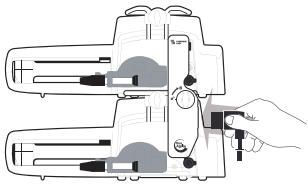
Location	Comments
<p>On a Pole</p> 	<p>☞ See section 5.3.1, page 29.</p> <p>Pole specifications:</p> <ul style="list-style-type: none"> ▪ Diameter: from 15 to 40 mm
<p>On a Rail</p> 	<p>☞ See section 5.3.2, page 29.</p> <p>Rail specifications:</p> <ul style="list-style-type: none"> ▪ Height: from 25 to 35 mm ▪ Depth: from 8 to 10 mm
<p>On the Link Agilia Rack</p> 	<p>☞ Refer to the Agilia Link accompanying documents.</p>
<p>On a Table</p> 	<p>☞ See section 5.3.3, page 30.</p> <p>Only install a pump on a table if it is not possible to attach it to a pole, a rail or recommended Agilia accessory.</p>
<p>On Another Pump</p> 	<p>☞ See section 5.3.4, page 30.</p>
<p>On an Agilia Duo</p> 	<p>☞ Refer to the Agilia Duo accompanying documents.</p>

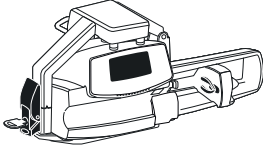
Location		Comments
In an Agilia Holder Ambulance		<p>☞ Refer to the Agilia Holder Ambulance accompanying documents.</p>

Do not use accessories that appear to be damaged. For more information on accessories, refer to their respective accompanying documents.



Warning

- *The pump must be used in a horizontal and stable position to function properly.*
- *Use recommended Agilia accessories to ensure stability and prevent the pump from falling. Do not stack the pump with equipment other than those recommended.*

5.2 Using the Rotating Pole Clamp

The rotating pole clamp is located at the back of the pump.

When installing the pump on a pole or a rail, fasten the rotating pole clamp firmly to avoid any movement of the pump.

5.2.1 Rotating Pole Clamp Description

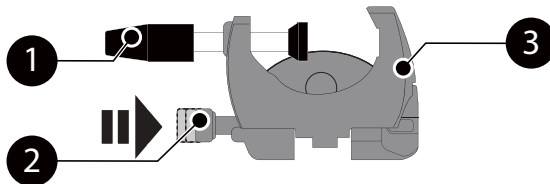

Figure 5.1: Rotating Pole Clamp System

Legend

- ① Screw Clamp
- ② Release Button
- ③ Rotating Pole Clamp

5.2.2 Using the Rotating Pole Clamp

You can secure the rotating pole clamp vertically or horizontally by folding it outward until the release button clicks into the locked position.

5.2.2.1 *Folding the Clamp Down (outward)*

You can fold the clamp down as follows:

1. Push the release button.
2. Fold the clamp outward.

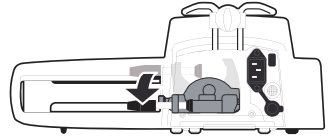

5.2.2.2 *Folding the Clamp Up (inward toward the pump)*

You can fold the clamp up as follows:

1. Push the release button.
2. Fold the pole clamp inward toward the pump.

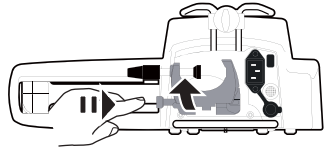

5.2.2.3 *Rotating the Clamp*

You can rotate the clamp as follows:

1. Fold the clamp up (see above).
2. Rotate the clamp to a vertical position.
3. If necessary, fold the clamp outward (see above).

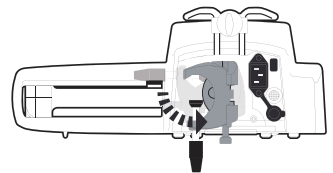

5.3 Attaching the pump(s)

5.3.1 Attaching to a Pole

1. Fold the pole clamp down to the horizontal position: see section 5.2.2.1, page 28.
2. Unscrew the clamp, attach to the pole, and screw the clamp until the pump is fully secured to the pole.
3. Make sure that the pump is securely attached.

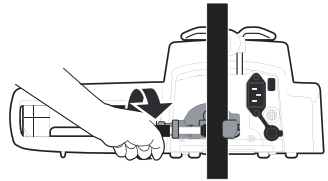

For more information on installing the pump on a pole, consult the pole's Instructions for Use.

Information



When installed on a rolling stand, do not tip over the system more than 5°: it may fall.

5.3.2 Attaching to a Rail

Only single pumps can be attached to a bed rail or gurney rail.

1. Rotate the pole clamp to the vertical position: see section 5.2.2.3, page 28.
2. Unscrew the clamp, attach to the rail, and screw the clamp until pump is fully secured to the rail.
3. Make sure that the pump is securely attached.

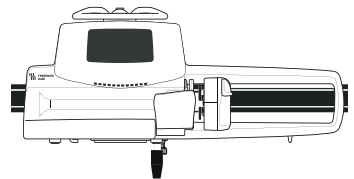
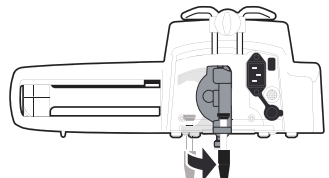

5.3.3 Using on a Flat Table

1. Fold the pole clamp up: see section 5.2.2.2, page 28.
2. Place the pump far enough from the table's edges to prevent it from accidentally being pushed off.

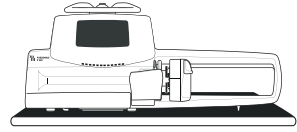



5.3.4 Attaching Two Pumps Together

You can attach two pumps together either for transport, or before fixing them to a pole.

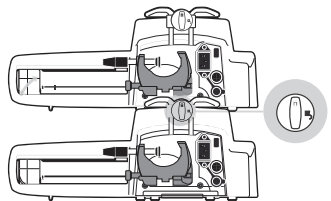
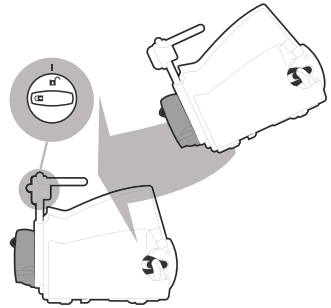
1. Fold both pumps' pole clamps up: see section 5.2.2.2, page 28.
2. Slide the slot on the bottom of the upper pump onto the handle of the lower pump.
3. Turn the attachment lock knob on the lower pump handle clockwise until the locked symbol lines up with the marker.
4. Make sure the two pumps are securely attached together.
5. If needed, fold the two pole clamps down and secure them tightly to the pole.



Symbol	Location	Description
	Attachment Lock Knob	Locked Position
	Attachment Lock Knob	Unlocked Position

6 Getting Started

6.1 Flowchart

Once the pump is installed at the bedside, you must follow the steps below in order to install a syringe and power on the pump.

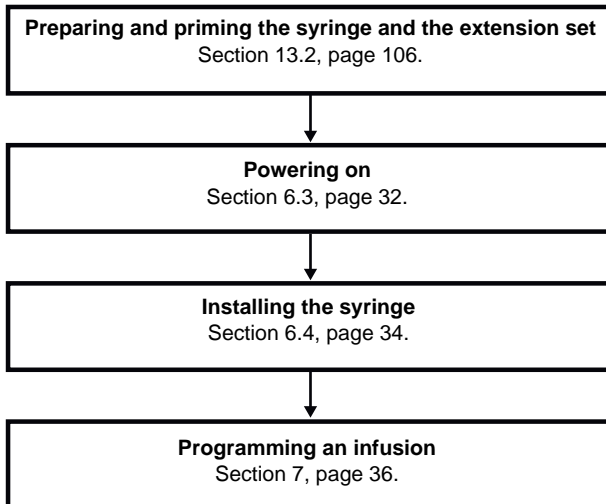

Information



In order to ensure that all the safety features of the device are activated, make sure that the following instructions are applied:

- *The pump is powered on prior to being connected to the patient.*
- *The pump is not connected to the patient during the set-up.*

6.2 Using the Pump for the First Time

1. Make sure the pump is correctly installed at the bedside.
See section 5, page 26.
2. Plug the pump into the AC power supply.
See section 17.1, page 122.
3. Before starting the pump for the first time, you must charge the battery for approximately **6 hours**.
Wait until the pump is fully charged.
Do not use the pump during the first charge.
4. Power on the pump.
See section 6.3, page 32.
5. Install a syringe into the pump.
See section 6.4, page 34.



6.3 Powering on

Information

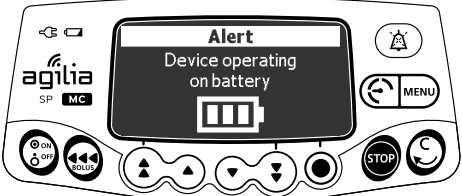

- *The pump can operate using the battery; however, we recommend that the pump be connected to a power supply as often as possible during use in order to ensure that the battery remains charged.*
- *When the pump is connected to the power supply, check that the power supply indicator  lights up green, and that the power cord and the wall plug are accessible.*

1. Press .
An auto-test checks the functionality of the pump.
2. Immediately after powering on the pump, make sure that all LED lights blink.
3. Acknowledge the different screens listed in the table below.

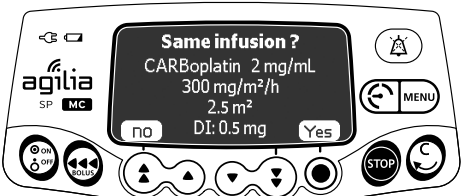
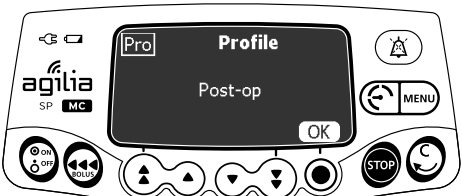
Screen After Powering on	Description
	<p>Startup screen: the following information is displayed:</p> <ul style="list-style-type: none"> Product name / Ward name Wi-Fi module status (if applicable) Date & time
	<ul style="list-style-type: none"> The pump is operating on battery. The symbol shows three different charge levels: <ul style="list-style-type: none"> < 30 % battery charge 30 % - 70 % battery charge > 70 % battery charge
	<ul style="list-style-type: none"> No syringe is installed on the pump. Syringe installation !!! is displayed on top of the screen. <ul style="list-style-type: none"> Install a syringe. See section 6.4, page 34.
	<ul style="list-style-type: none"> Maintenance reminder message (optional).
	<ul style="list-style-type: none"> Same infusion screen (optional). Press Yes to keep previous infusion settings.
	<ul style="list-style-type: none"> Profile confirmation screen (optional). Press Ok to confirm the profile. <p><i>Note: This screen is linked to the "same infusion" function above.</i></p>

Screen After Powering on	Description
	<ul style="list-style-type: none"> ▪ Data Set information (optional)

6.4 Installing a Syringe



Warning

This must only be done when the patient is not connected.

1. Open the syringe barrel clasp [A].
2. Push the disengagement lever [B] down and move the plunger driver to the right.
3. Place the syringe in its cradle, with the flanges correctly inserted in the provided slot.
4. Secure the syringe with the syringe barrel clasp [A].
5. Push the disengagement lever [B] and move the plunger driver gently to the left until it is in contact with the plunger head.
6. Check the general installation.

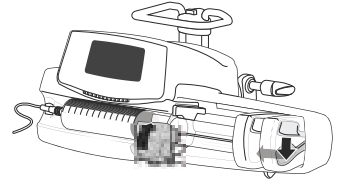
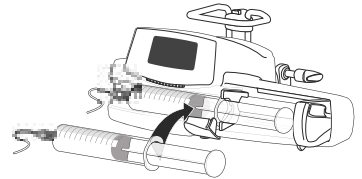
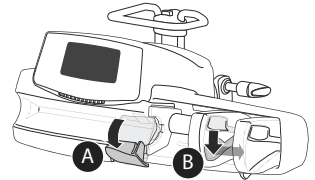

6.5 Pump Height

Warning



Ideally, the syringe pump should be level with the distal tip of the catheter (e.g., the site of fluid delivery; if accessing a central line the syringe pump should be at the level of the patient's heart). If the pump height is raised relative to the distal tip of the catheter (e.g., during patient transport), the increase in height of the syringe pump can result in a temporary increase in fluid delivery or bolus until the flow rate stabilizes. Alternatively, if the pump is lowered relative to the distal tip of the catheter, the decrease in height of the syringe pump may result in a decrease in delivery or under-infusion until the flow rate stabilizes.

Precautions for pump position

- If using multiple syringe pumps and it is not clinically feasible to have all pumps level with the distal tip of the catheter (or the site of fluid delivery), place the high risk or life-sustaining medications as close to level with the distal tip of the catheter as possible. When infusing multiple high risk or life-sustaining medications, consider placing the ones infusing at the lowest rates as close to the level with the distal tip of the catheter as possible.
- Minimize the height difference between the pump and the patient and avoid changes in the height of the pump (e.g., during transport of critically ill patients) to prevent unintended fluctuations in the flow rate.

7 Operation

7.1 Flowchart

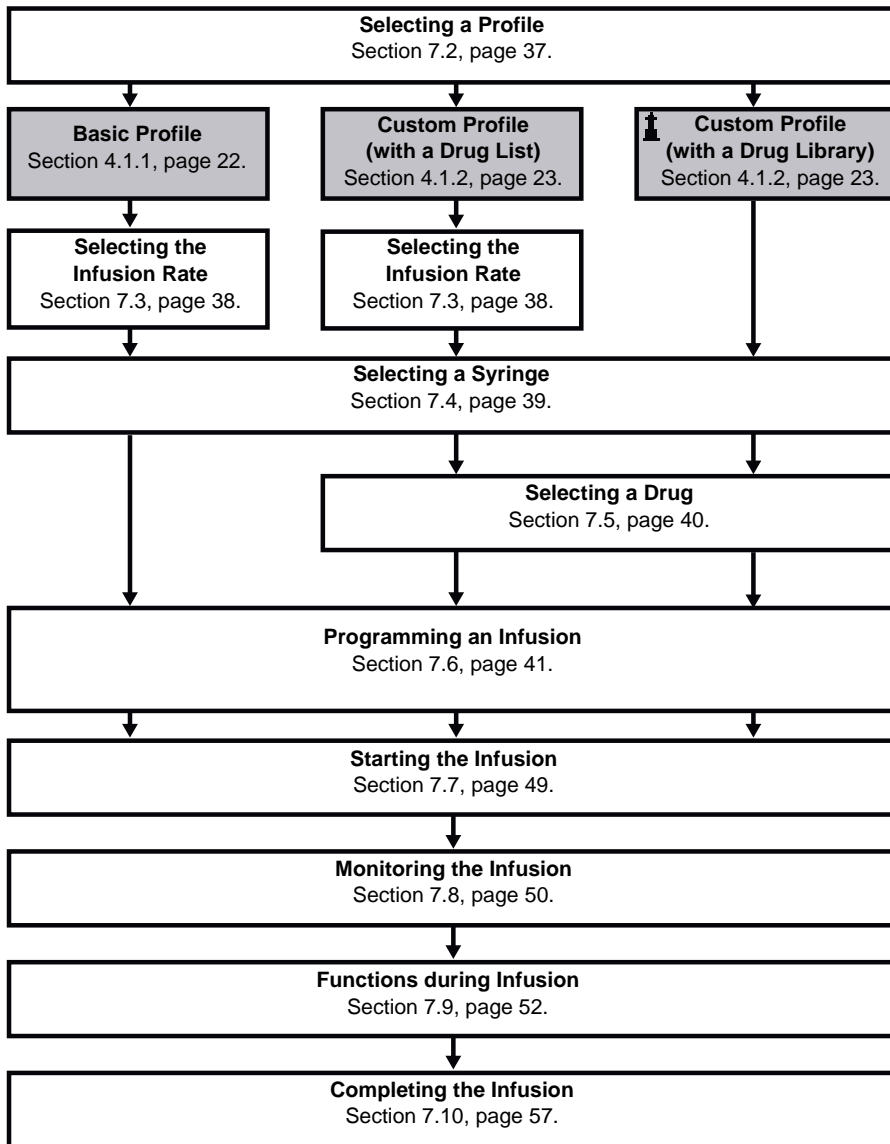

7.2 Selecting a Profile

You can only select a profile if more than one profile is loaded in the pump.

1. Press  to power on the pump.



2. Press the arrow keys to select a profile that corresponds to the target group of patients.

The  (lighthouse) symbol refers to custom profiles that contain drug libraries and have been configured with Agilia Vigilant Drug Lib software.

3. Press **OK** to confirm.

The selected profile information is displayed.



4. Press **OK** to confirm the drug library version, or **C** to change the profile.

The drug library is loaded for the profile selected.

7.3 Selecting the Infusion Rate (Flow Rate or Dose)

The programming mode step allows you to select the infusion rate. This step occurs just after selecting Basic Profile, or a custom profile with a drug list.

Note: The infusion rates for each drug of a drug library are pre-defined with Agilia Vigilant DrugLib software.

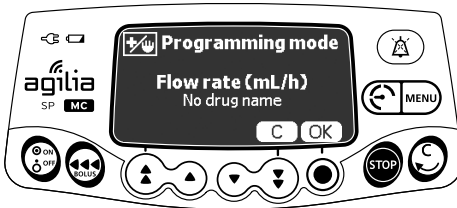

Flow rate

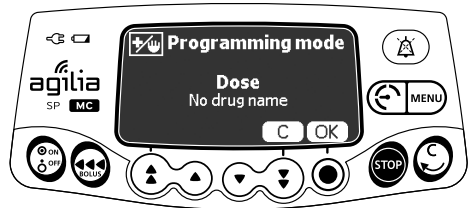

Dose

The infusion rate that was last used is displayed.

1. Press **OK** to confirm the infusion rate or press **C** to change it.

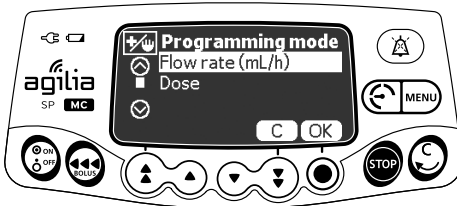

Flow rate

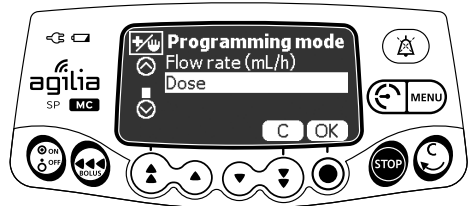

Dose

2. Press the arrow keys to select a new infusion rate.
3. Press **OK** to confirm.

7.4 Selecting a Syringe

The pump automatically detects the size of the installed syringe.

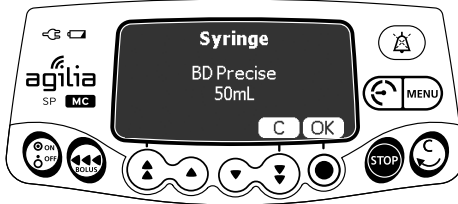

1. Press **OK** to confirm the displayed syringe, or **C** to change it.



2. If you have chosen to select another syringe, press the arrow keys to select a new syringe.
3. Press **OK** to confirm the new syringe.
A clinical advisory message may appear, if one is configured for the selected syringe.

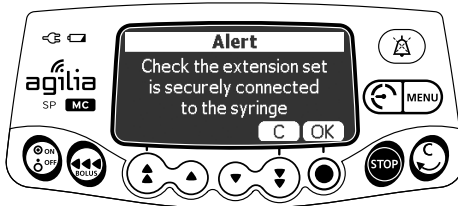

4. Press **OK** to acknowledge the clinical advisory message, or **C** to return to the syringe selection screen.

Warning



During programming and prior to starting an infusion, verify that the syringe size and model on the syringe pump's display screen matches the syringe size and model loaded onto the syringe pump.

7.5 Selecting a Drug

Note: The drug selection step is not applicable with Basic Profile.

Drugs are sorted alphabetically by the first letter of their names:

- A → C
- D → F
- G → I
- J → L
- M → O
- P → R
- S → U
- V → Z
- Drug X (mL/h)

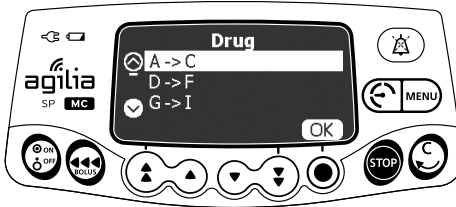

1. Press the arrow keys to scroll to the drug's first letter, and press **OK**.

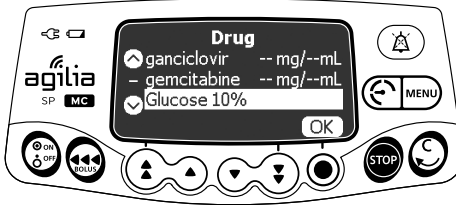

2. Press the arrow keys to scroll to the drug's name, and press **OK**.
A clinical advisory message may appear, if one is configured for the selected drug.
3. Press **OK** to acknowledge the clinical advisory message and continue programming, or **C** to change the drug.

7.6 Programming an Infusion

- This section describes the programming of an infusion with the **Simple Rate** infusion mode.
- You can also program an infusion with the following modes:
 - Volume/Time (or Dose/Time), see section 7.11.2, page 59.
 - Volume Limit, see section 7.11.3, page 60.

7.6.1 Programming an Infusion by Flow Rate

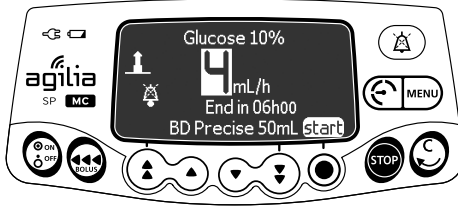

1. Press the arrow keys to program the flow rate.

7.6.2 Programming an Infusion by Dose

7.6.2.1 Selecting the Drug Concentration

Profile	Drug Concentration Selection Procedure
Basic Profile	A- Basic Profile and Custom Profiles (with a Drug List), page 41.
Custom Profile (with a drug list)	
 Custom Profile (with a drug library)	B- Custom Profiles, page 42.

A- Basic Profile and Custom Profiles (with a Drug List)

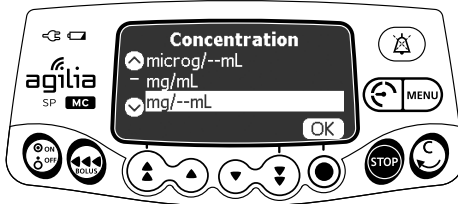

1. Press the arrow keys to select the drug concentration unit, and press **OK**.

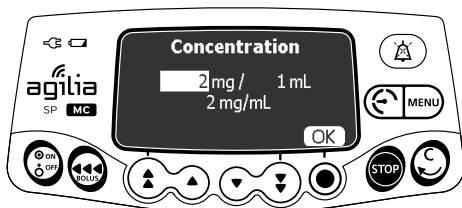

2. Press the arrow keys to select a mass value, and press **OK**.
3. Press the arrow keys to select a volume value, and press **OK**.
The concentration is automatically calculated and displayed in the unit selected above.
4. Press **OK** to confirm.

B- Custom Profiles

The selected drug is configured in Agilia Vigilant Drug'Lib software to allow adjustments to its concentration in one of the following ways:

- Within an authorized range
- At authorized finite values (up to 5)

If no adjustment of the concentration is allowed, see section 7.6.2.2, page 44.

Authorized Concentration Range

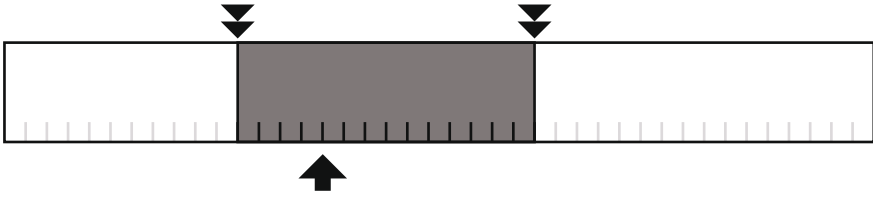

Authorized Finite Concentrations

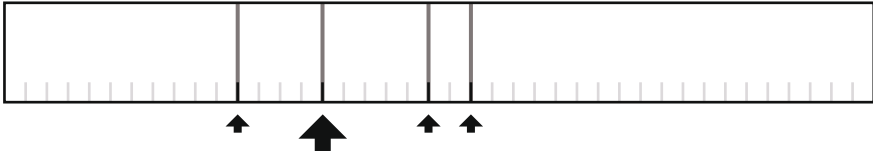

Legend

 Unauthorized Range

 Authorized Range

 Hard Limits

 Default Value

 Finite Values

Selecting the Drug Concentration

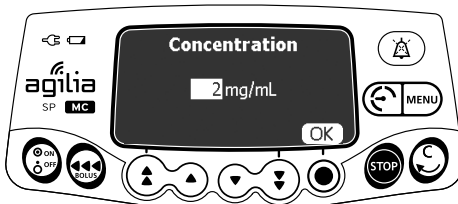

Range

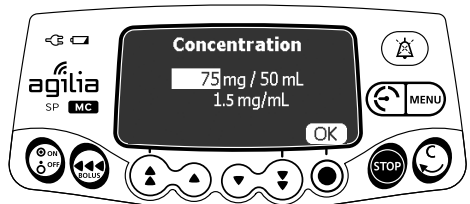

Finite values

1. Press the arrow keys to select the concentration.
2. Press **OK** to confirm.

7.6.2.2 Selecting the Patient's Characteristics

Note: This step is only applicable with custom profiles that contain a drug library.

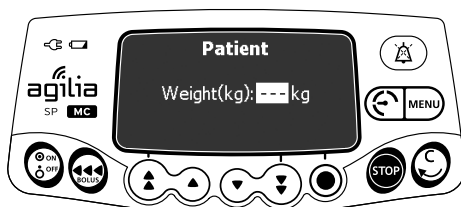

Weight

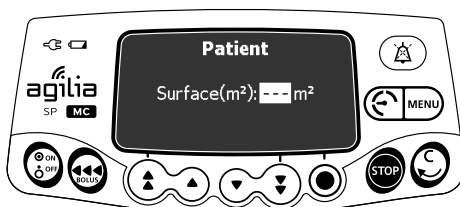

Body Surface Area

1. Press the arrow keys to enter the patient's weight or body surface area.
2. Press **OK** to confirm.

Information

- The weight entry screen only appears if the selected drug uses weight for dose rate calculations.
- The body surface area entry screen only appears if the selected drug uses body surface area for dose rate calculations.
- A pre-populated default weight or body surface area will be configured with the Agilia Vigilant Drug'Lib software.



7.6.2.3 Selecting the Infusion Unit

Note: This step is only applicable with Basic Profile and custom profiles that contain a drug list. The infusion units for each drug of a drug library are pre-defined with Agilia Vigilant Drug'Lib software.

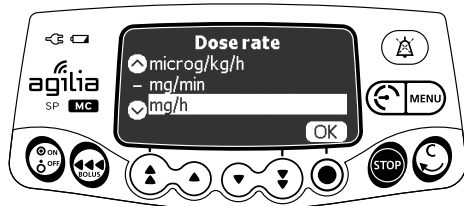

1. Press the arrow keys to select the infusion unit.
2. Press **OK** to confirm.

7.6.2.4 Programming the Infusion

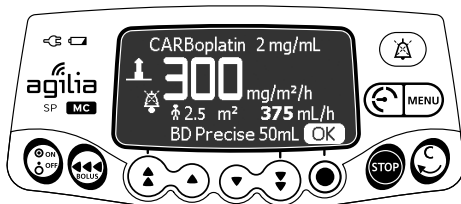

1. Press the arrow keys to program the dose rate value.
2. Press **OK** to confirm.

7.6.2.5 Programming a Loading Dose

Note: This feature can be activated or deactivated in Agilia Vigilant Drug'Lib software (custom profiles).

Information



The loading dose is only available with the first start of an infusion. If **no** is pressed inadvertently, power the pump off and then on to access the loading dose again.

If enabled for the selected drug, you can program a **loading dose** after programming an infusion defined by dose.

The screens below will appear prior to starting the infusion.

Selecting a Loading Dose

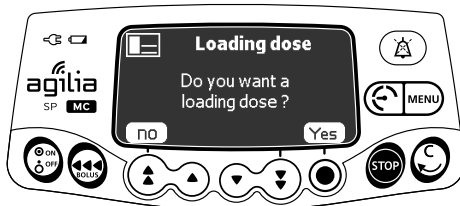

On the loading dose screen:

- Press **no** to return to the programming screen.
- Press **Yes** to program a loading dose prior to starting the infusion.

Programming a Loading Dose

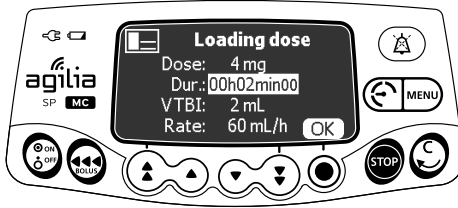

1. Press the arrow keys to enter a value for the dose, and press **OK** to confirm.
2. Press the arrow keys to program the loading dose duration (__ h __ min __), and press **OK** to confirm each time segment.
The VTBI and the flow rate are automatically calculated based on dose and duration settings.
3. Press **OK** to confirm the loading dose settings.
*If needed, press **C** or  to change the loading dose settings before starting.*

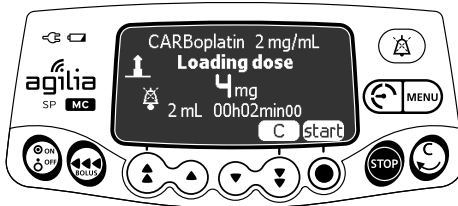

4. Press **start** to initiate the loading dose.
Once the loading dose is finished, the pump automatically starts the programmed infusion.

Interrupting a Loading Dose

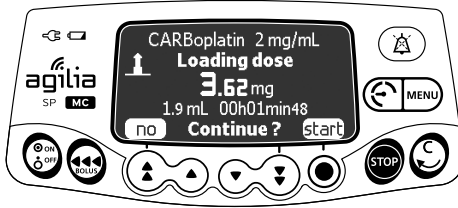

1. To pause the loading dose, press **STOP**.
The screen displays `Continue?`
2. Choose one of the following options:
 - Press **no** or **STOP** to stop the loading dose and proceed to the programmed infusion.
 - Press **start** to continue with the loading dose.

7.6.3 Programming Beyond Soft Limits

Note: This step is only available with custom profiles that contain a drug library.

You can override soft limits, and adjust flow rate and dose within the authorized ranges. You cannot override a hard limit.

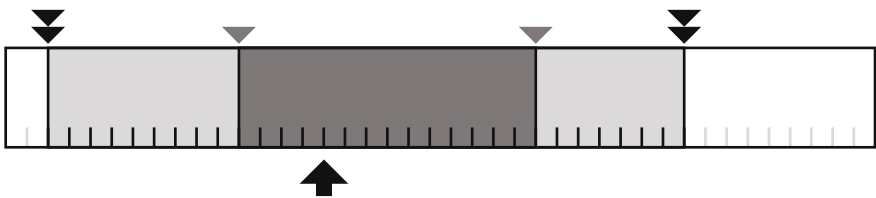

Legend

	Unauthorized Range		Hard Limits
	Programmable Range (warning and confirmation)		Soft Limits
	Authorized Range		Default Value

Overriding a Soft Limit

1. If you receive a soft limit when programming an infusion, the pump displays a message at the top of the screen:
 - Upper soft max = the upper soft limit is exceeded
 - Lower soft min = the lower soft limit is exceeded

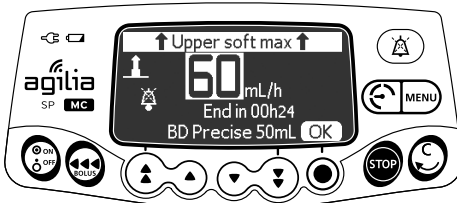

Flow rate

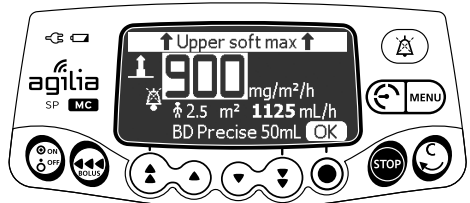

Dose

2. If the displayed settings correspond to the intended flow rate or dose, press **OK**.

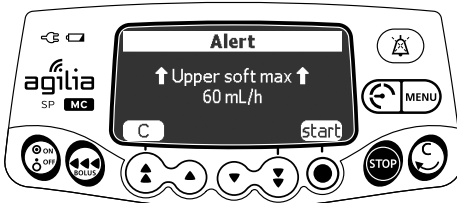

Flow rate

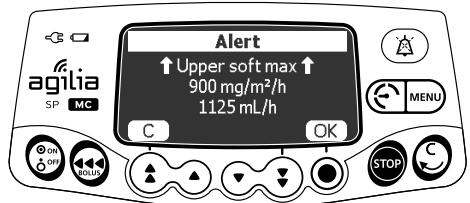

Dose

3. Carefully review the program settings.
The original infusion settings continue until you confirm the new settings.
4. Press **OK** or **start** to confirm the soft limit override.

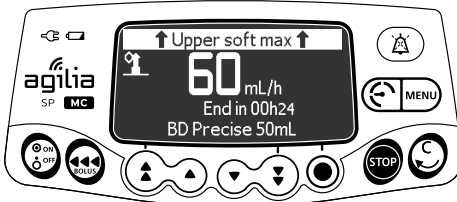

Flow rate

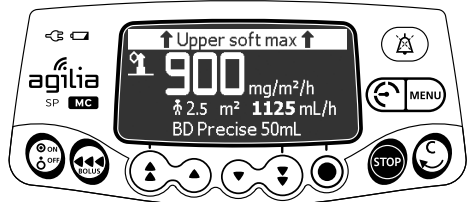

Dose

During infusion, the upper or lower soft limit message will alternate with the drug name and concentration at the top of the screen.

7.7 Starting an Infusion

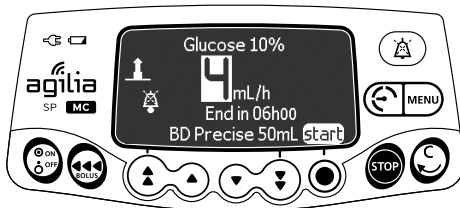

Flow rate

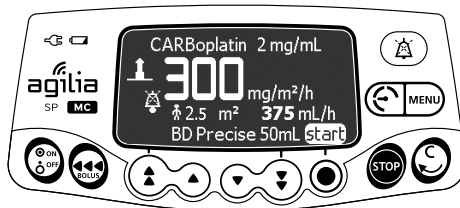

Dose

1. Check the delivery path integrity, (syringe and access device).
2. Check that there is no air in the syringe or in the extension set.
3. Confirm that the syringe is correctly installed in the pump.
4. Connect the syringe's extension set to the patient's access device.
5. Check the infusion settings prior to starting the infusion.
6. Press **start** to start the infusion.

Warning



- *When connecting the syringe's extension set to the patient's access device, always use aseptic technique according to your healthcare facility policy.*
- *During programming and prior to starting an infusion, verify that the syringe size and model on the syringe pump's display screen matches the syringe size and model loaded onto the syringe pump.*

Information



- *If the syringe is not correctly positioned in the pump, we recommend clamping, closing or disconnecting the extension set from the patient's access device.*

7.8 Monitoring an Infusion

7.8.1 Monitoring an Infusion when Programmed by Flow Rate

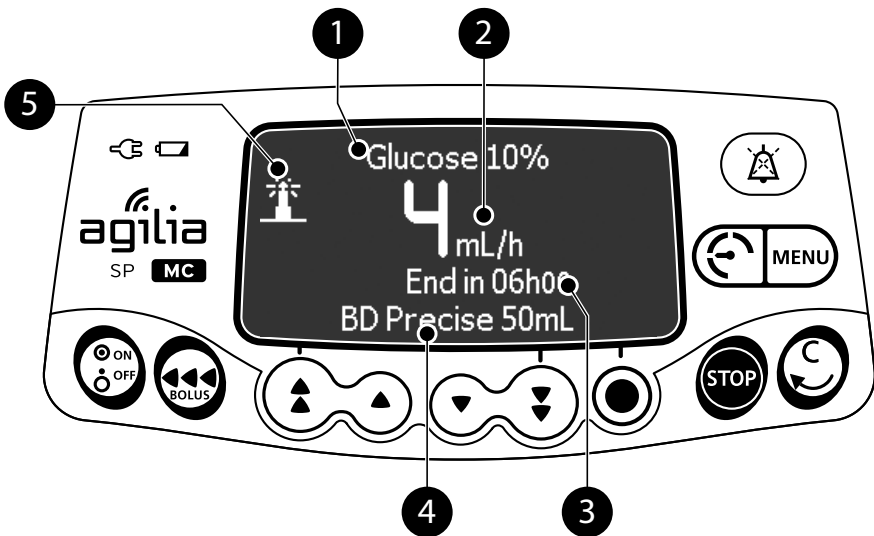

Legend

- 1 **Drug Name (Custom profiles only)**
 - 2 **Infusion Flow Rate (mL/h)**
To change the flow rate during an infusion, see section 7.9.2, page 52. The flow rate is displayed with the largest font size.
 - 3 **Infusion Duration**
At the current rate, the remaining infusion time in hours and minutes. Infusion duration may or may not be displayed depending on the configuration preset with Agilia Vigilant Drug'Lib software for this drug.
 - 4 **Syringe Name / Ward Name (configurable)**
 - 5 **Custom Profile Sign**
 When infusing a drug selected from the Agilia Vigilant Drug'Lib software library, this lighthouse sign is displayed on the screen continuously.
-

7.8.2 Monitoring an Infusion when Programmed by Dose

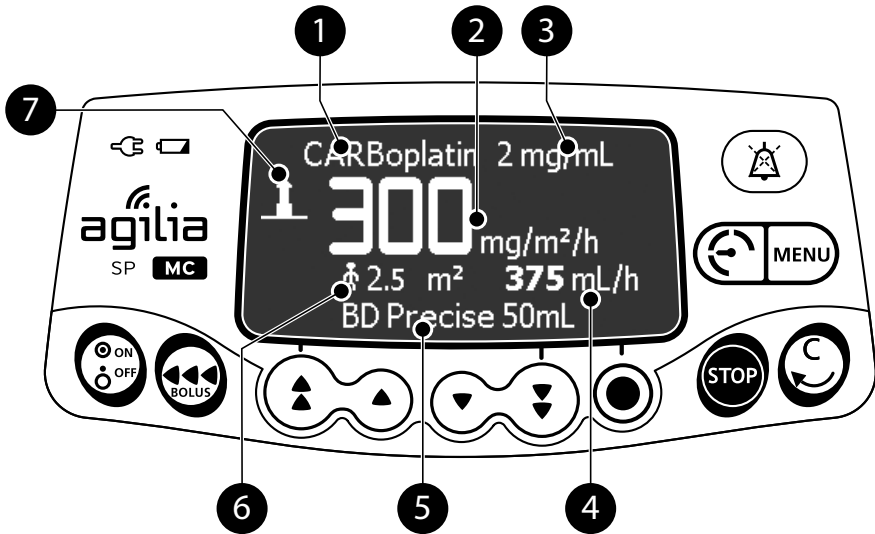

Legend

- 1 **Drug Name (Custom profiles only)**
 - 2 **Dose**
To change the dose during an infusion, see section 7.9.2, page 52.
Dose is displayed with the largest font size.
 - 3 **Drug Concentration**
 - 4 **Infusion Flow Rate**
 - 5 **Syringe Name / Ward Name (configurable)**
 - 6 **Patient Characteristics**
 - 7 **Custom Profile Sign**
 When infusing a drug selected from the Agilia Vigilant Drug'Lib software library, this lighthouse sign is displayed on the screen continuously.
-

7.9 Functions During Infusion

7.9.1 Stop



Flow rate

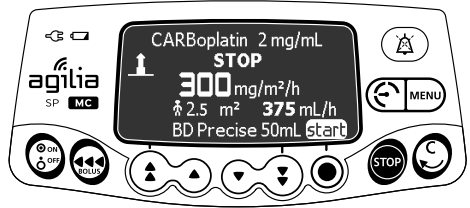

Dose

To stop the infusion, press **STOP**.

After 2 minutes, an alarm is generated as a reminder that the infusion is stopped.

To restart the infusion, first confirm or modify the programming settings, then start the infusion. See section 7.6, page 41.

7.9.2 Rate Titration

You can adjust the infusion rate (flow rate or dose) during the infusion. Depending on your pump configuration, stopping the infusion may be required before modifying the infusion rate.

1. If required, stop the infusion, see section 7.9.1, page 52.
2. Press the arrow keys to modify the flow rate or dose.
3. Press **OK** to confirm.

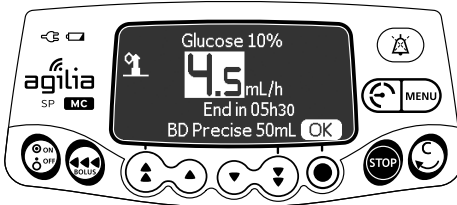

Flow rate

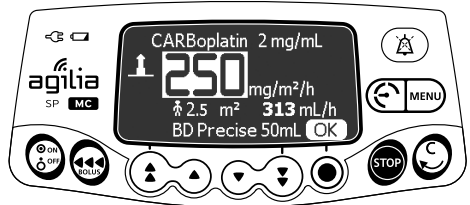



Dose

7.9.3 Administering a Bolus

A **bolus** is an extra dose that a pump can deliver during an infusion.

There are two ways to deliver a bolus dose during an infusion:

- Direct bolus
- Programmed bolus

	Direct Bolus	Programmed Bolus
Access Key		 or 
Occlusion Pressure Level	Set to its maximum value: 900 mmHg / 120 kPa / 17.4 PSI	





Information

- *The bolus volume is added to the Volume Infused (VI).*
- *The  key is not active when the menu screen is displayed.*

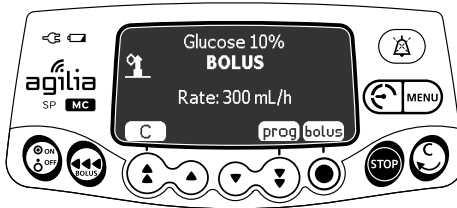

7.9.3.1 Direct Bolus

Note: This feature can be activated or deactivated in Agilia Vigilant DrugLib software (custom profiles) or in the pump options (Basic profile).



1. During the infusion, press .
2. Press **bolus** to confirm access to bolus function.





3. To administer a direct bolus, press and hold .
4. Monitor the volume infused on the main display until the desired bolus is reached.
5. To stop the bolus, release the  key.
The infusion resumes its previous rate after the bolus is delivered.

7.9.3.2 Programmed Bolus

Note: This feature can be activated or deactivated in Agilia Vigilant Drug'Lib software (custom profiles) or in the pump options (Basic profile).

During the infusion, you can program a bolus in one of the following two ways:

- Press , then **prog.**
- Press , and select  in the menu. Press **enter** to confirm.

Programming a Bolus

1. Press the arrow keys to program the bolus volume or dose, and press **OK**.
2. Press the arrow keys to program the bolus duration (h min), and press **OK**.
The flow rate is calculated automatically.

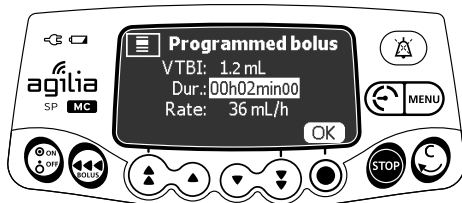

Flow rate

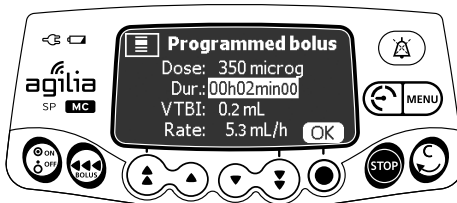

Dose

3. Press **start** to start the bolus.

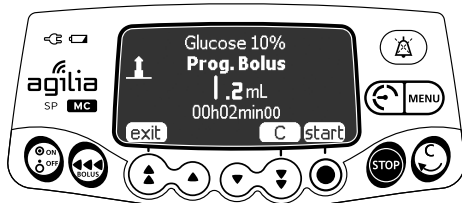

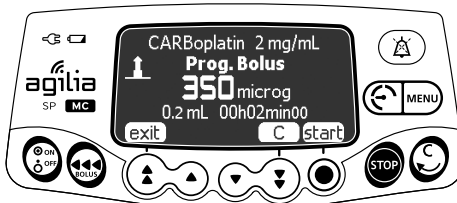

Flow rate



Dose

The infusion resumes its previous rate after the bolus is delivered.

Press **exit** or  to exit the bolus function and save the programmed bolus settings.

If you press  again, this screen appears immediately and displays the settings of the last bolus.

Interrupting a Programmed Bolus

1. Press  to interrupt the bolus.

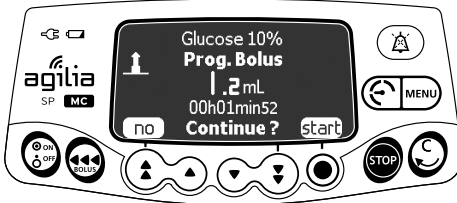

Flow rate

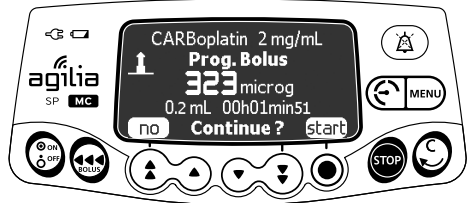

Dose

2. Answer the question: Continue?
 - Press **no** to return to the infusion.
 - Press **start** to continue the bolus.

7.10 Completing an Infusion

7.10.1 Near End of Infusion Alert

Prior to the end of an infusion, a **near end of infusion** alert is automatically triggered. The following happens:

- An audible alarm is triggered.
- An alarm message appears on the pump screen.
- The infusion indicator lights flash yellow.

Near end of infusion alert is triggered when the two criteria below are reached simultaneously.

Setting	Range of Values	Default Pump Setting
Time Before the End of the Infusion	From 1 to 30 minutes	5 minutes
The remaining volume of fluid in the syringe < 10 % of the syringe capacity	N/A	N/A

Near end of infusion alert settings are configurable with Agilia Vigilant Drug'Lib software (custom profiles), or in the pump options (Basic Profile). For more information, refer to the technical manual.

Silencing Near End of Infusion Alert

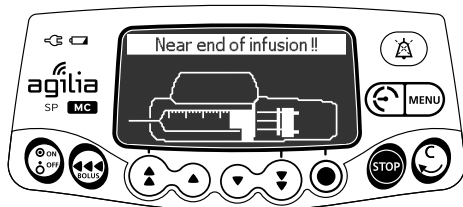

1. Press  to silence the alarm.
2. If required, press **OK** to confirm the **empty syringe** mode.

Depending on the pump configuration, the following happens:

- *The infusion continues at the programmed rate until the plunger reaches the tip of the syringe. The syringe is not completely emptied (regular end of infusion).*
- *The infusion continues until the syringe is completely emptied. The flow rate decreases when the plunger reaches the tip of the syringe (empty syringe - only in Simple Rate mode).*

7.10.2 End of Infusion

When the infusion is complete, the following happens:

- An audible alarm is triggered.
- An alarm message appears on the pump screen.
- The infusion indicator lights flash red.

End of infusion settings are configurable with Agilia Vigilant Drug'Lib software (custom profiles), or in the pump options (Basic Profile). For more information, refer to the technical manual.

Silencing the Alarm

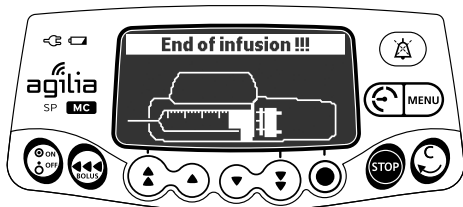

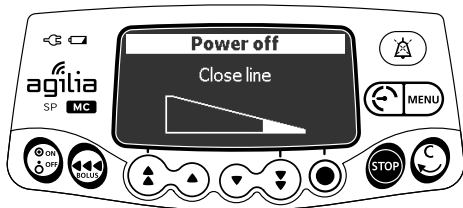

1. Press  to silence the alarm.
2. Prepare a new syringe, and adjust the settings for a new infusion.

7.10.3 Powering off



You can power off the pump as follows:

1. Press  to stop the infusion.
2. Press and hold  until the pump powers off.

7.11 Infusion Modes

You can program an infusion with the different infusion modes available, depending on the pump configuration, and on the selected drug.

7.11.1 Simple Rate

1. Press the arrow keys to select the infusion rate.
2. Press **OK**.

For more information, see section 7.6, page 41.

7.11.2 Volume/Time & Dose/Time

You can use this infusion mode to program a volume to be infused (VTBI) over a programmed period of time.

When the VTBI is reached, an alarm is triggered.

1. For information on how to access the **Volume/Time** or **Dose/Time** menu, see section 8.11, page 78.

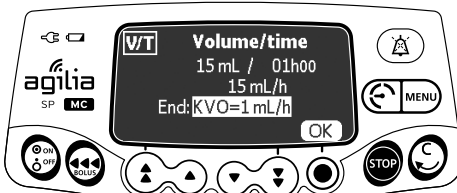

Volume/Time

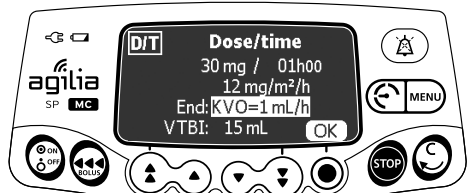

Dose/Time

2. Press the arrow keys to set the volume or dose to be infused (VTBI / DTBI), and press **OK**.
The infusion rate is automatically calculated.

Information



If you program a volume to be infused that is greater than the actual volume in the syringe, make sure to replace the syringe when it is empty, see section 13.3.2, page 106.

3. Press the arrow keys to set the infusion time, and press **OK**.
The infusion rate is automatically readjusted.
4. Press the arrow keys to configure the end of infusion settings and press **OK** to confirm.
 - *Stop*: The infusion stops when the VTBI is completed.
 - *Keep Vein Open (KVO)*: After the VTBI is completed, the infusion continues at a preset flow rate to keep the access device open.
 - *Continuous*: After the VTBI is completed, the infusion continues at the programmed flow rate.

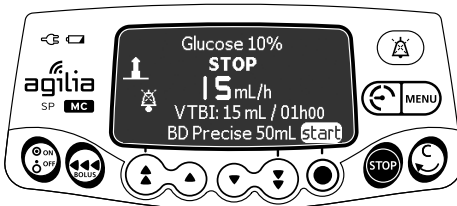

Volume/Time

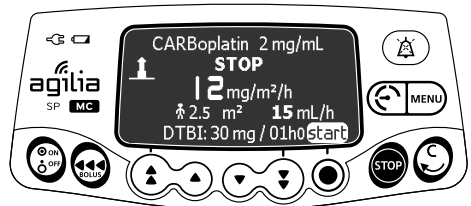

Dose/Time

5. Press **start** to start the infusion.

7.11.3 Volume Limit

You can use this infusion mode to set a limit to the volume infused. When the limit is reached, an alarm is triggered.

1. Access the **Volume Limit** menu, see section 8.12, page 78.

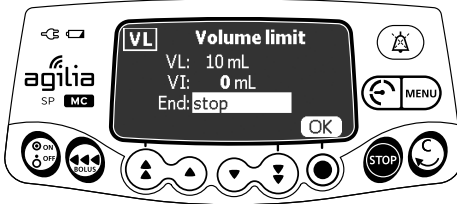

Flow rate

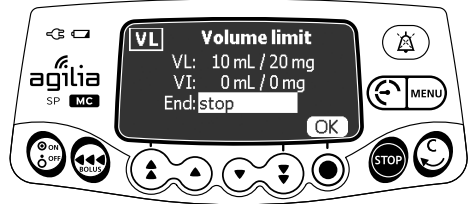

Dose

2. Press the arrow keys to set the volume limit, and press **OK**.

Information



- If you program a volume limit that exceeds the actual volume in the syringe, make sure to replace the syringe when it is empty, see section 13.3.2, page 106.
 - The volume already infused (VI) before accessing the volume limit mode is taken into account.
3. Press the arrow keys to configure the end of infusion settings and press **OK** to confirm.
- **Stop:** The infusion stops when the volume limit is reached.
 - **Keep Vein Open (KVO):** After the volume limit is reached, the infusion continues at a preset flow rate to keep the access device open.
 - **Continuous:** After the volume limit is reached, the infusion continues at the programmed flow rate.

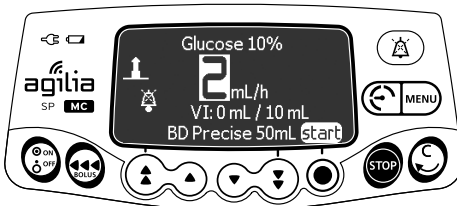

Flow rate

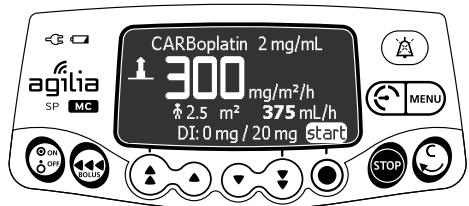

Dose

4. Press **start** to start the infusion.

7.12 Other Functions

7.12.1 Priming the Syringe and the Extension Set

Note: The prime function can be configured with Agilia Vigilant Drug'Lib (custom profiles) or in the pump options (Basic profile):



- **Mandatory:** A message is displayed and the user is required to prime the line before infusion.
- **Advised:** A message is displayed to encourage the user to prime the line before infusion.
- **Not displayed:** The pump does not remind the user to prime the line before infusion.

Information



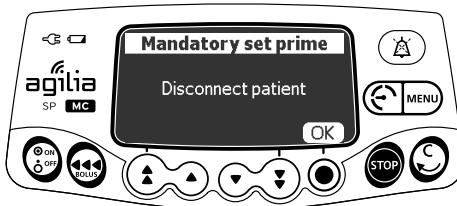

We strongly recommend to always use the prime function, especially for life-sustaining drugs. Priming the syringe and the extension set removes all the mechanical gaps and ensures that the programmed flow rate is reached within the smallest delay once the start button is pressed.



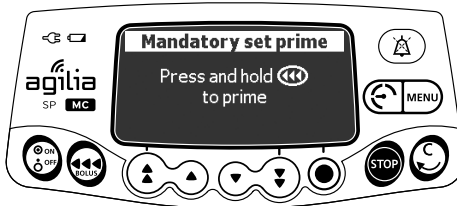

1. Press  to power on the pump.
2. Press .
3. Make sure the extension set is not connected to the patient, as indicated on the screen.
4. Press **OK** to proceed.



5. Press and hold the  key to prime.
6. To end priming, release the  key.
7. Make sure there is no air in the extension set.

Information



- Priming is only accessible prior to starting the infusion.
- The  key is not active when the menu screen is displayed.
- During priming, the occlusion pressure level is set to its maximum value 900 mmHg / 120 kPa / 17.4 PSI.
- Priming is limited to 5 mL maximum. Above 5 mL, you must release and press the  key again to restart priming.

Quick-Start

Quick-start is designed to decrease the delay of therapy when the pump's prime function is not used.

When quick-start is triggered, the infusion starts at a high flow rate (120 mL/h) until the pump's plunger driver starts pushing the syringe plunger head. The flow rate then automatically switches to the programmed value.

At the beginning of an infusion, quick-start is triggered or not triggered in the following situations:

Prime Function Configuration	Quick-start Trigger Rule
Mandatory	<ul style="list-style-type: none"> ▪ Not triggered
Advised	<ul style="list-style-type: none"> ▪ Not triggered
Not displayed	<ul style="list-style-type: none"> ▪ Triggered if flow rate is equal or inferior to 50 mL/h <u>and</u> the automatic priming is not done. ▪ Not triggered if the automatic priming is done by the user.

Information



Priming the line automatically ensures better pump performances than using quick-start.

Warning



If the prime function is set as "Not displayed", and if the quick-start is triggered, an undesired bolus may occur in some cases. Always prefer the automatic prime function for life-sustaining drugs.

7.12.2 Pre-programming the Pump

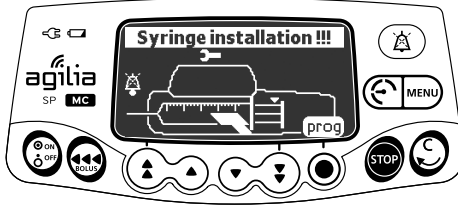

You can program the pump before installing the syringe.

1. Press  to power on the pump.
Syringe installation !!! is displayed on top of the pump screen.
2. Make sure the syringe barrel clasp is folded up against the pump.
*The **prog** symbol is displayed.*
3. Press **prog**.
4. Program the infusion.
See section 7.6, page 41.

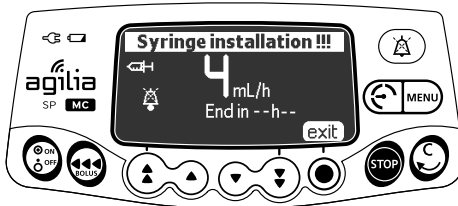







5. Press **exit** to confirm.
6. When ready, install the syringe.
7. Press **start** to start the infusion.









8 Menus









8.1 Overview

8.1.1 Commands

Operation	Key
Access menu or exit menu	
Select	   
Confirm	 (corresponds to enter on the screen)
Select <input checked="" type="checkbox"/> / Deselect <input type="checkbox"/>	

8.1.2 Menu Description

Menu	Symbol	Stop Infusion Required	Associated Procedure
Profile	Pro	NO	<ul style="list-style-type: none"> ▪ Displaying active profile information, page 66.
Pressure		NO	<ul style="list-style-type: none"> ▪ Modifying the pressure limit, page 67.
Keypad lock status		NO	<ul style="list-style-type: none"> ▪ Locking / Unlocking the keypad, page 70.
Battery life		NO	<ul style="list-style-type: none"> ▪ Viewing the battery life, page 72.
Volume Infused	mL?	NO	<ul style="list-style-type: none"> ▪ Viewing and clearing the volume or dose infused, page 73.
Dose Infused			
Pause		YES	<ul style="list-style-type: none"> ▪ Programming a pause, page 74.
Programmed bolus		NO	<ul style="list-style-type: none"> ▪ Programming a bolus, page 75.
Patient		NO	<ul style="list-style-type: none"> ▪ Changing a patient's weight or body surface area, page 75.
Day/Night mode		NO	<ul style="list-style-type: none"> ▪ Switching between day mode and night mode, page 76.
Volume/Time	V/T	YES	<ul style="list-style-type: none"> ▪ Programming a Volume/Time or Dose/Time infusion, page 78.
Dose/Time	D/T	YES	
Volume limit	VL	YES	<ul style="list-style-type: none"> ▪ Programming a Volume Limit infusion, page 78.
Alarm volume		NO	<ul style="list-style-type: none"> ▪ Adjusting the alarm volume, page 79.
Volume-Dose history		YES	<ul style="list-style-type: none"> ▪ Viewing the infusion history, page 80.

Menu	Symbol	Stop Infusion Required	Associated Procedure
View flow rate history		NO	▪ Viewing flow rate history, page 81.
View pressure history		NO	▪ Viewing pressure history, page 82.
Syringe		NO	▪ Displaying on-pump syringe information, page 83.
View event log		NO	▪ Viewing the event log, page 84.
Date / Time		NO	▪ Setting the date and time, page 85.
Maintenance		NO	▪ Displaying maintenance information, page 86.
Library information		NO	▪ Displaying drug library information, page 87.
Clinical information		NO	▪ Viewing remaining time before clinical information display, page 88.
Data Set	DS	NO	▪ Displaying active data set information, page 89.

Note: The displayed menu may change depending on the pump configuration.

For more information on factory configuration, refer to Appendix: Factory Configuration, page 153.

8.2 Profile

Symbol	Pro
Procedure	Displaying active profile information

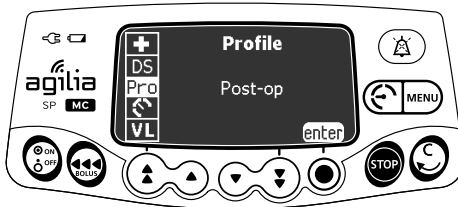

You can display the active profile name as follows:

1. Press .
2. Press the arrow keys to select Pro .
3. Press **enter**.

The active profile information is displayed.



8.3 Pressure

Symbol	
Procedure	Modifying the pressure limit

The pump pressure limit is pre-defined in the pump options in one of the following modes:

- 3 levels** (low , medium , high).
 The pressure limit is adjustable according to 3 pre-set values.
- Variable** .
 The pressure limit is adjustable within a pre-defined range.

When the pressure limit is reached, an occlusion alarm is triggered. You must silence the alarm, resolve the occlusion and start the infusion again.

To consult the pressure settings, see section 15.8, page 113.



Warning

When addressing or clearing an occlusion:

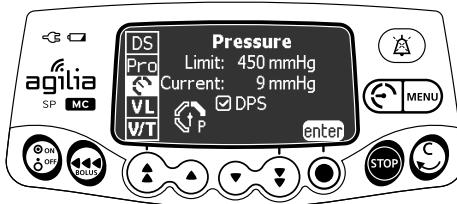
- Ensure the fluid flow to the patient is OFF to prevent administering an unintended bolus. An occlusion may pressurize the infusion tubing and syringe, which can result in an unintended bolus of drug when the occlusion is cleared. In order to prevent this additional bolus, disconnect the tubing, or relieve the excess pressure through a stopcock, if present. The health care professional should weigh the relative risks of disconnection with the risks of an unintended bolus of drug.*
- Be aware that using larger size syringes on a high plunger force setting may produce a larger post occlusion bolus due to excessive syringe plunger head compliance.*





You can modify the pressure limit as follows:

1. Open the pressure menu in one of the two following ways:
 - Press .
 - Through the Menu:
 - Press .
 - Press the arrow keys to select .
2. Press **enter** to access the pressure limit screen.

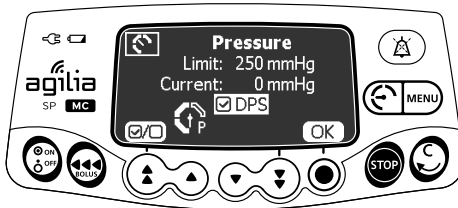

3. Press the arrow keys to increase or decrease the pressure limit.
4. Press **OK** to validate.



5. Press  to enable or disable the DPS function (optional).
6. Press **OK** to confirm.



Warning

To avoid the presence of air and to minimize the amount of time it takes the pump to recognize an occlusion and generate an alarm while infusing at low rates (e.g., less than 5 mL per hour, and especially flow rates less than 0.5 mL per hour):

- Consider occlusion pressure threshold setting and adjust it, as necessary. The lower the occlusion pressure threshold setting, the shorter the occlusion detection time. However, when infusing viscous or thick fluids (e.g., lipids), the occlusion pressure threshold setting may need to be adjusted to reduce false alarms.
- Use the smallest compatible syringe size necessary to deliver the fluid or medication. This minimizes the amount of friction and compliance (i.e., stiffness) of the syringe plunger head. Because syringe pumps infuse fluids by precisely controlling the plunger, smaller syringes provide more precise fluid delivery than larger syringes.
- Use the prime feature on the pump when changing a syringe and/or tubing.
- Use extension set which have the smallest internal volume or deadspace (e.g., use microbore tubing when infusing at low rates, shorter length of tubing, etc.).



Information

- The Dynamic Pressure System (DPS) informs the user of any sudden rise or drop in pressure before the pressure limit is reached.
- If variable pressure mode is enabled, a pre alarm is triggered when the pressure reaches 50 mmHg below maximum pressure (25 mmHg when maximum pressure is 50 mmHg).
- If other pumps are used in parallel, it is recommended that their pressure limits be adjusted to the same level.

8.4 Keypad Lock Status

Symbol	
Procedure	Locking / Unlocking the keypad

You can use this feature to avoid inadvertent key presses.



Note: The following features can be activated or deactivated in the pump options:

- *Automatic lock: The keypad will lock automatically at infusion start, or after a time-out.*
- *Unlock code: The user must enter a code to unlock the keypad.*

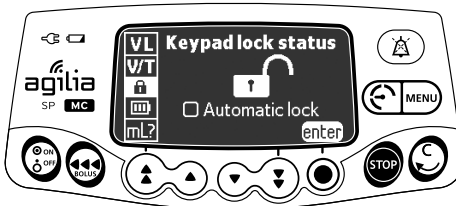
Locking the Keypad



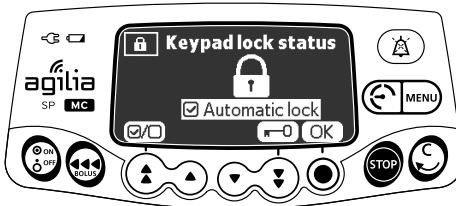

You can lock the keypad as follows:

1. Press .
2. Press the arrow keys to select .
3. Press **enter**.



4. Lock the keypad as follows:



- Press  to lock the keypad.
The keypad is locked and the screen displays  .
- Press  to activate the automatic lock.
The keypad will lock automatically at infusion start. If the keypad is unlocked during the infusion, it will lock again automatically after a time-out.

5. Press OK to confirm.

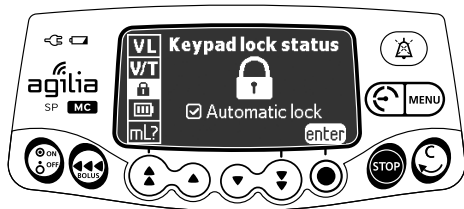
Unlocking the Keypad



You can unlock the keypad as follows:

1. Press .
2. Press the arrow keys to select  .
3. Press **enter**.

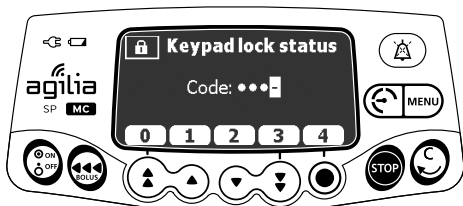

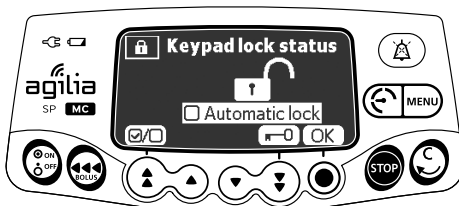

Unlock code enabled







Unlock code disabled

4. Unlock the keypad as follows:

- If a code is required, press the keys to enter the unlock code.
The keypad is unlocked.
- If no code is required, press  , and press **OK** to confirm.
The keypad is unlocked and the screen displays  .

Information

- The  and  keys remain functional when the keypad is locked.
- During keypad lock, the  key is functional when the infusion is stopped.
- During keypad lock, the  key is functional when an alarm occurs, or at the end of infusion.
- The keypad locked status is memorized when the pump is powered off.
- In case of forgotten unlock code, contact your biomedical department.



8.5 Battery Life

Symbol	
Procedure	Viewing the battery life

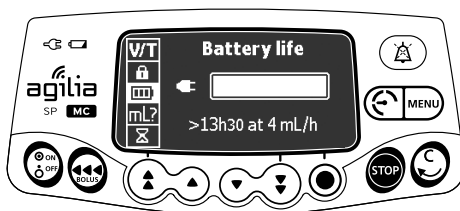



You can view the battery life as follows:

1. Press .
2. Use the arrow keys to select .
The time remaining under current flow rate conditions is displayed.

The bar graph shows a visual representation of battery life.

The symbol displayed shows the following:

- : The pump is plugged into the AC power supply.
- : The pump is operating on battery.

8.6 Volume Infused / Dose Infused

Symbol	mL?
Procedure	Viewing and clearing the volume or dose infused

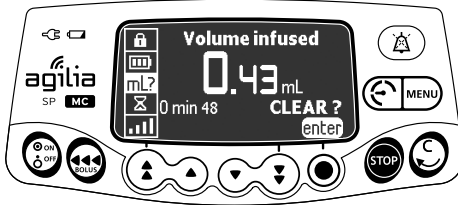

Flow rate

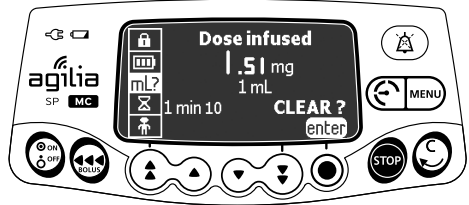

Dose

You can view and clear the volume or dose infused as follows:

1. Press **MENU**.
2. Press the arrow keys to select mL? .
The total volume, or total dose, infused includes the programmed infusion, loading doses and boluses. The length of time over which they were infused is also displayed.
3. To clear the volume or dose infused, press **enter**.
4. Press **OK** to confirm.



Information



When the pump is powered off or a new drug is selected, the volume or dose infused is cleared.

8.7 Pause

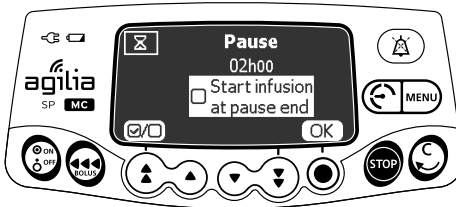
Symbol	
Procedure	Programming a pause



You can program a pause as follows:

1. Press **STOP** to stop the infusion.
2. Press **MENU**.
3. Press the arrow keys to select .
4. Press **enter**.
5. Press the arrow keys to program the pause duration in hours and minutes, and press **OK**.
6. Press the button to activate the "Start infusion at pause end" feature. (optional)
7. Press **OK** to begin the programmed pause.
8. To restart the infusion before the end of the pause period, press  then **start**.

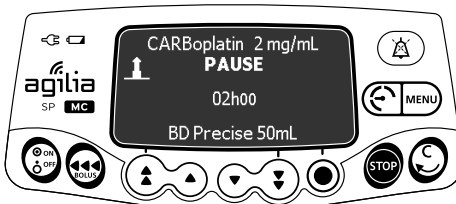

Information



If you do not activate the "Start infusion at pause end" option, an audible alarm is generated at the end of the pause. The infusion must be started manually to continue the infusion.

8.8 Programmed Bolus

Symbol	
Procedure	Programming a bolus

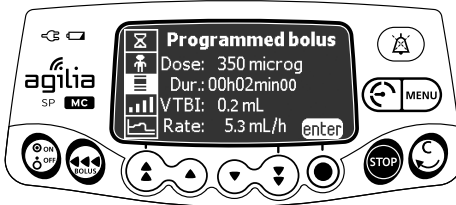

To program a bolus, see section 7.9.3.2, page 55.

8.9 Patient

Symbol	
Procedure	Changing a patient's weight or body surface area

Information



- If the selected dose rate unit is weight-based (kg), the screen displays the patient's weight.
- If the selected dose rate unit is body surface area-based (m²), the screen displays the patient's body surface area.

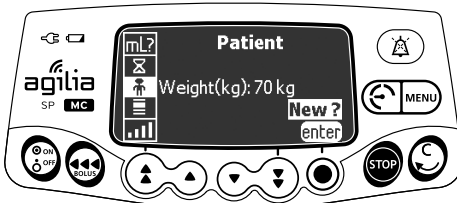

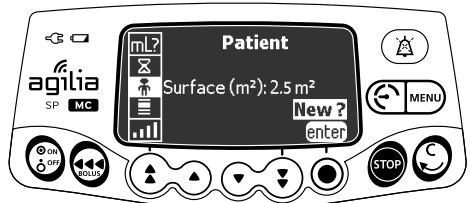

Weight





Body Surface Area

You can change the patient's weight or body surface area as follows:

1. Press .
2. Press the arrow keys to select .
3. Press **enter**.
4. Press **OK** to change the patient's weight or body surface area.
5. Press **OK** to confirm the infusion settings.

8.10 Day/Night Mode

Symbol	
Procedure	Switching between day mode and night mode

This function switches between day mode  and night mode .

The default night mode settings are as follows:



- The key-press beep is silenced.
- Infusion indicators and screen brightness are dimmed.

Depending on your pump configuration, the switch between day and night mode may be managed either through this menu (manual mode), or according to pre-defined settings (auto mode). For more information, refer to the technical manual.

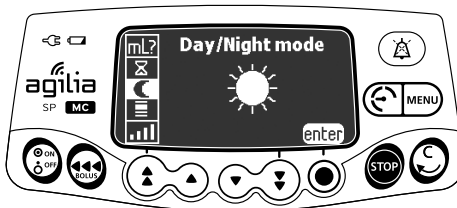
Switching from Day Mode to Night Mode



You can switch to night mode as follows:

1. Press .
2. Press the arrow keys to select .
3. Press **enter**.

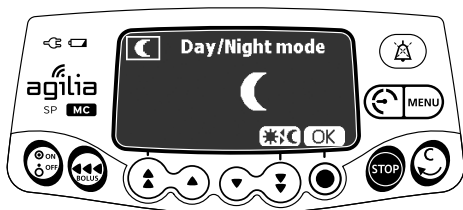

4. Press to activate night mode.

The screen displays .

5. Press OK to confirm.

Switching from Night Mode to Day Mode

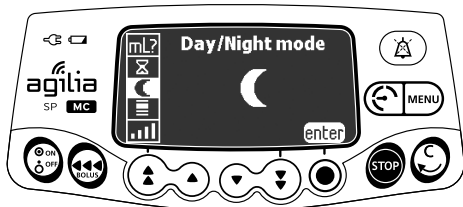

You can switch to day mode as follows:

1. Press .
2. Press the arrow keys to select .
3. Press **enter**.

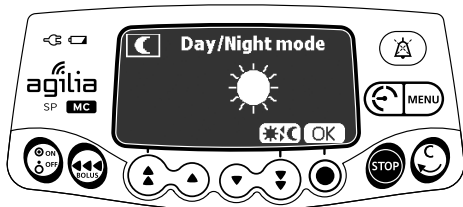

4. Press to activate day mode.

The screen displays .

5. Press OK to confirm.

8.11 Volume/Time & Dose/Time

Symbols	V/T D/T
Procedure	Programming a Volume/Time or Dose/Time infusion

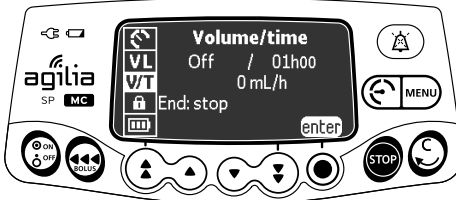

Volume/Time

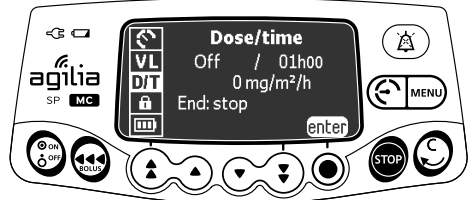

Dose/Time

1. Press .
2. Press the arrow keys to select V/T (or D/T).
3. Press **enter**.

For more information on how to program a Volume/Time or Dose/Time infusion, see section 7.11.2, page 59.

8.12 Volume Limit

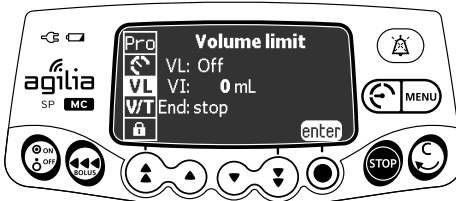

Symbol	VL
Procedure	Programming a Volume Limit infusion

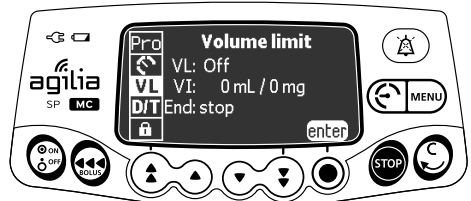

Flow rate



Dose

1. Press .
2. Press the arrow keys to select VL .
3. Press **enter**.



For more information on how to program a Volume Limit infusion, see section 7.11.3, page 60.

8.13 Alarm Volume

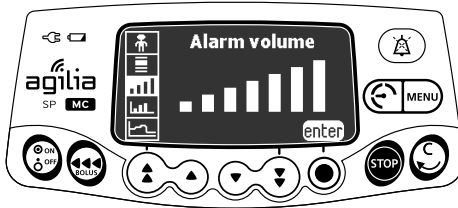
Symbol	
Procedure	Adjusting the alarm volume



You can adjust the alarm volume as follows:

1. Press .
2. Press the arrow keys to select .
3. Press **enter**.
4. Press the arrow keys to select the alarm volume.
The pump emits an alarm at the selected volume level.
5. Press **OK**.

8.14 Volume-Dose History

Symbol	
Procedure	Viewing the infusion history

This function allows the user to view the infusion history on the pump.

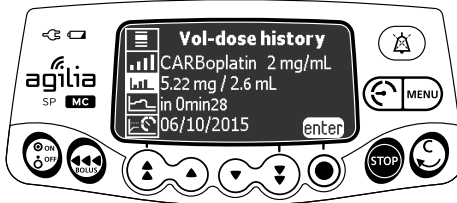

You can view the infusion history as follows:

1. Press **MENU**.
2. Press the arrow keys to select .
3. Press **enter**.

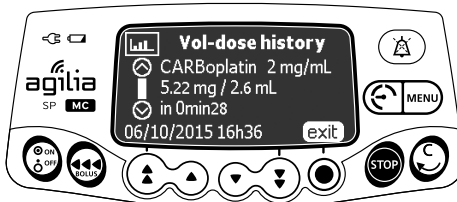

4. Press the arrow keys to select the desired infusion.
The selected infusion's details are displayed:
 - Drug name
 - Drug concentration
 - Volume or dose infused
 - Infusion total duration
 - Infusion date & time
5. Press **exit** to return to the menu.



8.15 View Flow Rate History

Symbol	
Procedure	Viewing flow rate history

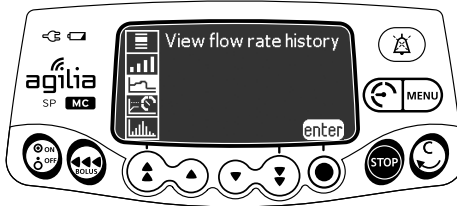
This function allows the user to check the current infusion's history information in order to verify the dose administered.



You can view flow rate history as follows:

1. Press .
2. Press the arrow keys to select .
3. Press **enter**.
The following information is displayed:
 - An event marker (cursor)
 - The event details (time and flow rate)
 - The measured flow rate (solid line)

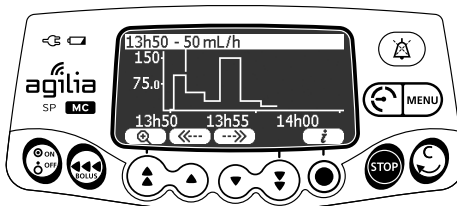

4. Press the  and  buttons to browse the events.
5. Press  to view information about the selected event.

Information



- *The history is not refreshed while the history screen is displayed. To refresh the history data, exit and select the history again.*
- *Flow rate history is not stored after powering off.*



8.16 View Pressure History

Symbol	
Procedure	Viewing pressure history

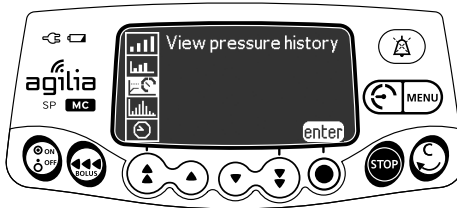
This function allows the user to check the current infusion's history information in order to verify changes in pressure.



You can view pressure history as follows:

1. Press .
2. Press the arrow keys to select .
3. Press **enter**.
The following information is displayed:
 - An event marker (cursor)
 - The event details (time and pressure limit)
 - The pressure limit (dotted line)
 - The measured pressure (solid line)

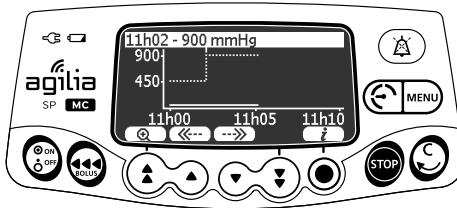

4. Press the  and  buttons to browse the events.
5. Press  to view information about the selected event.

Information





- The history is not refreshed while the history screen is displayed. To refresh the history data, exit and select the history again.
- Pressure history is not stored after powering off.

8.17 Syringe

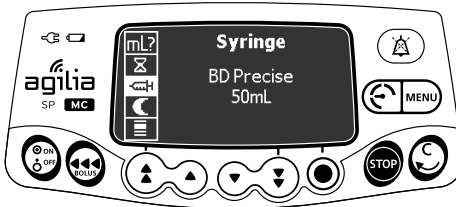
Symbol	
Procedure	Displaying on-pump syringe information



You can display on-pump syringe information as follows:

1. Press .
2. Use the arrow keys to select .
3. Press **enter**.
The following information is displayed:
 - Syringe capacity
 - Syringe brand / name

8.18 View Event Log



Symbol	
Procedure	Viewing the event log

The event log displays details of the last events that occurred on the pump. Events are stored in the log even after the pump is powered off and on again. The log can store up to 1500 events. Older events are overwritten.

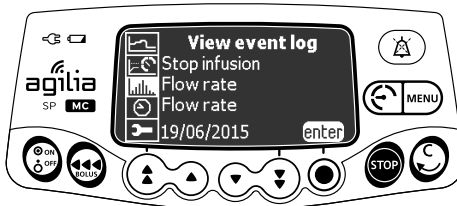
Note: When the AC Power is disconnected for a period of time, or when the batteries are not operating, the log file is kept in a non-volatile memory for approximately 10 years.



You can view the event log as follows:

1. Press .
2. Press the arrow keys to select .
3. Press **enter**.

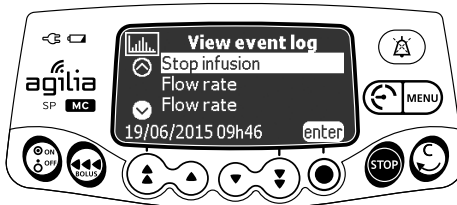

4. Press the arrow keys to select the desired event.
5. Press **enter**.
The details of the event are displayed.

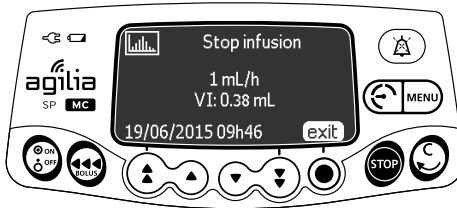

6. Press **exit** to return to the previous screen.

8.19 Date / Time

Symbol	
Procedure	Setting the date and time

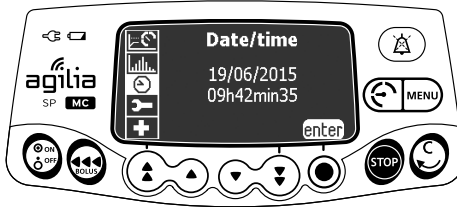

You can set the date and time as follows:



1. Press **MENU**.
2. Press the arrow keys to select
3. Press **enter**.
4. Press the arrow keys to set the following:
 - Day
 - Month
 - Year
 - Hours
 - Minutes
5. Press **OK** to confirm.

8.20 Maintenance

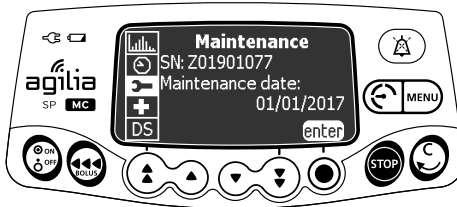
Symbol	
Procedure	Displaying maintenance information



You can display maintenance information as follows:

1. Press .
2. Press the arrow keys to select .
3. Press **enter**.
4. Press the arrow keys to scroll through the maintenance information.

The following information is displayed:



- *Pump serial number*
- *Next maintenance date (dd/mm/yyyy)*
- *Pump model*
- *Software version*
- *Total operating time since last maintenance*

8.21 Library Information

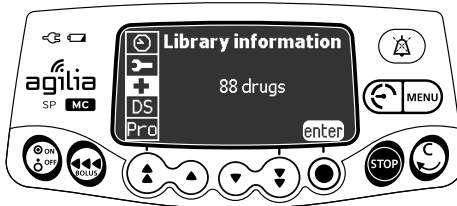
Symbol	+
Procedure	Displaying drug library information



You can display drug library information as follows:

1. Press .
2. Press the arrow keys to select .
The number of drugs contained in the drug library is displayed.
3. Press **enter**.
All the drugs contained in the drug library are displayed.

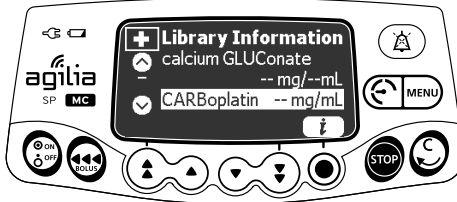

4. Press the arrow keys to select a drug.
5. Press  to view information on the selected drug.

8.22 Clinical Information

Symbol	+ ⚠
Procedure	Viewing remaining time before clinical information display

If configured for the selected drug with Agilia Vigilant Drug'Lib, a protocol message will be displayed on the pump screen after a pre-defined period of time.

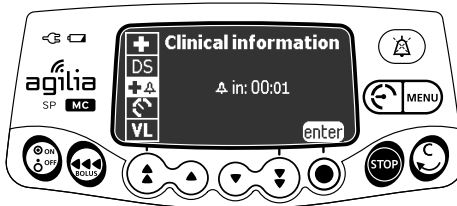

You can view the remaining time before clinical information display as follows:

1. Press **MENU**.
2. Press the arrow keys to select **+ ⚠**.
The remaining time before clinical information is displayed.
3. Press **enter**.
The clinical information message is displayed.

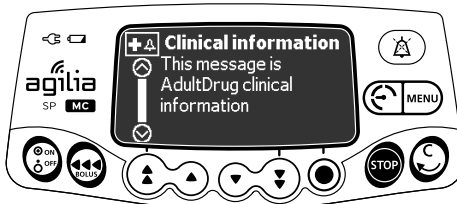

8.23 Data Set

Symbol	DS
Procedure	Displaying active data set information

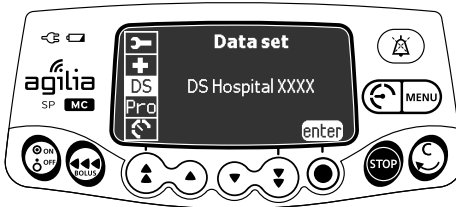





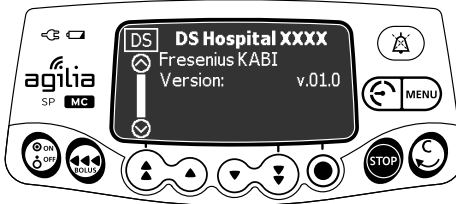

You can display active data set information as follows:

1. Press .
2. Press the arrow keys to select DS .
3. Press **enter**.
The active data set information is displayed.

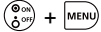

9 Options

9.1 Commands

Operation	Key
Options access	 + MENU
Option selection	   
Confirm	 (corresponds to enter on the screen)
Select <input checked="" type="checkbox"/> / Deselect <input type="checkbox"/>	

Selected current values are stored when the device is powered off after programming.
To return to the normal menus, power off then power on again.

9.2 Option Descriptions

Four different option groups are available on the pump. This IFU only describes the "Pump Settings" options.

Option	Access Code?	Description Location
Pump Settings	No	Section 9.3, page 91.
Basic Profile Configuration	Yes	Technical Manual
Profile	Yes	Technical Manual
Maintenance	Yes	Technical Manual



Information

If the wrong access code is entered, error is displayed.

9.3 Pump Settings

The following options have different functions that you can select or deselect to customize your Agilia SP MC.

Function	Choice	Default Pump Setting
[User 2]: Menu items	▪ Maintenance: display or hide maintenance	Disabled
	▪ Date / Time: display or hide date/time menu	Disabled
[User 3]: Contrast	▪ Adjustment of screen contrast using the fast increment and decrement keys	Medium level
[User 7]: Date/Time	▪ Date selection: dd/mm/yyyy	Production plant date and time
	▪ Time selection: __ h __	
[User 8]: Language	▪ A scrolling list with all available languages	Official language of the target country
[User 14]: Wi-Fi module	▪ Enable/Disable the Wi-Fi module	Enabled
[Par 5]: Syringe selection	▪ Enable/Disable selected syringe confirmation screen	Enabled
[Par 6]: Syringes	▪ Checkbox list with the names of available syringes, and other syringes sizes	Section 13.1, page 106.
[Par 13]: AC power disconnection alert	▪ Enable/Disable "AC power disconnection" message and "Device operating on battery" message at power on	Enabled
[Par 35]: Dose display format	▪ Enable/Disable display of the decimal "0" after a dose value	Remove trailing 0 / Remove trailing 0 during programming
[Par 37]: Alarm system	▪ Enable/Disable preventive silence for alarm system	Enabled
[Par 38]: Keypad unlock code	▪ Set or disable keypad unlock code (4-digit). Disable value: 0000	0000 (Disabled)

10 Data Communication

10.1 Overview

Cable Communication	Wi-Fi Communication
Connection of 1 pump to a PC for the following purposes: <ul style="list-style-type: none">▪ Data set upload (via Agilia Vigilant Drug'Lib software)▪ Maintenance (via Agilia Partner software)	Communication between a hospital information system server and a number of identified pumps for the following purposes: <ul style="list-style-type: none">▪ Data set upload▪ Pump history retrieval

Information



- *Ensure that all hospital information systems have been approved by **Fresenius Kabi**. For more information, contact your technical services representative.*
- *Before connecting the pump to a hospital information system, ask your IT or biomedical department to configure the device.*

10.2 Communication via Agilia Cables

10.2.1 Data Communication Cables

Information



- *Only use recommended Agilia cables.*
- *All connections and disconnections must be performed by qualified and appropriately trained staff.*
- *All IT devices (including computers, hubs and switches) inside the patient area (< 1.5 m) must comply with IEC/EN 60601-1 (leakage current).*
- *IT devices connected outside the patient area (> 1.5 m) must be at least IEC/EN 60950 compliant.*

10.2.2 Using the Communication Port

1. Remove the protective cap from the pump's RS232 communication port.
2. Connect the cable to the RS232 communication port by turning the cable wheel.

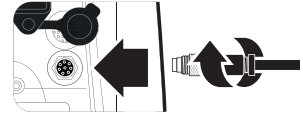
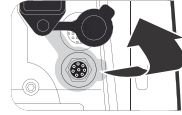

Information

Do not disconnect communication cables while data is being transferred.

10.3 Communication via Wi-Fi

The Wi-Fi option allows the pump to connect to a hospital information system without cables.

To know if your pump is equipped with a Wi-Fi module, check for the presence of the Wi-Fi logo on the pump's keypad.
See section 3.4.1, page 17.

agilia

Wi-Fi pump

agilia

Non Wi-Fi pump

To activate or deactivate the Wi-Fi module, see section 9.3, page 94.

For more information on the Wi-Fi module, refer to the technical manual.



Information

Wi-Fi pumps can be configured with Wi-Fi module enabled or disabled.

10.4 Data Set Upload

A new data set may be uploaded to the pump while it is infusing. The new data set will be installed at the next pump start-up.

When a new data set has been uploaded since the last start-up of the pump, the  symbol is displayed on the screen.

1. Power on the pump.

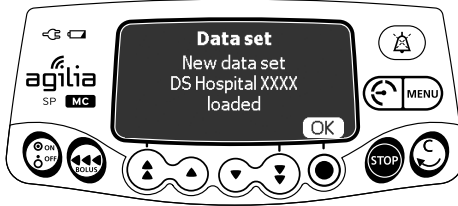

2. Press **OK** to acknowledge.
The data set information is displayed.



3. Press **OK** to acknowledge this information, or **C** to return to the previous screen.
The data set is installed in the pump.

Information



It is the hospital's responsibility to define a data set and upload it to the Centerium Server for distribution to the device.

11 User Test

The following protocol provides the user with a quick integrity check guide to ensure that the pump system is functional. Perform this user test before each use of the pump.

1. Check the external appearance of the pump for the absence of cracks or other visible damage.
2. Check for the absence of visible damage on the power cord inlet and the power cord.
3. When used on a pole or a rail, check that the pump is securely attached.
4. Connect the pump to the AC power supply, and check that the power indicator lights up and a beep is emitted.
5. Power on the pump, and wait for the auto-test to complete. Check the display and light indicators.
6. Press any key and listen for a key beep (if key beep is activated).

12 Alarms and Safety Features

12.1 Introduction

Agilia SP MC has a continuous monitoring system that begins when the pump is started.

When an alarm is triggered, a message is displayed on the pump screen. We recommend that the user stand in front of the pump to read the message before acknowledgment.





Warning

Audible alarm signals from medical devices may be masked by environmental noise. Make sure to set the alarm volume high enough so that you can hear the alarm signal above environmental noise.

12.2 Alarm Descriptions

There are several different levels of alarm priorities:

- High-priority alarms
- Medium-priority alarms
- Low-priority alarms
- Information signals

Alarm Priority	Required Operator Response	Description
High (!!!)	Immediate response	<ul style="list-style-type: none">▪ The infusion stops.▪ The infusion indicator lights flash red.▪ The pump emits audible alarm signals.▪ An alarm description is displayed on the pump screen.▪ The  key silences the alarm (for two minutes).
Medium (!!)	Prompt response	<ul style="list-style-type: none">▪ The infusion continues.▪ The infusion indicator lights flash yellow.
Low (!)	Awareness	<ul style="list-style-type: none">▪ The pump emits audible alarm signals.▪ The  key silences the alarm (for no time limit).
Information Signals	Awareness	<ul style="list-style-type: none">▪ The infusion continues.▪ An information message is displayed on the pump screen.

12.3 General Remarks

- When two alarms occur at the same time, the higher priority alarm is displayed.
- When two alarms with the same priority level are triggered at the same time, the pump software assigns them a priority.
- When the cause of a high-priority alarm has been fixed, the red indicators switch off. However, the message remains displayed at the top of the screen as a reminder of the cause of the alarm.
- The device guarantees the triggering of high-level priority alarms in every use condition.
- A maximum of 1 mL may be infused due to a single fault condition.
- For all alarms (except occlusion alarms), the amount of time between the alarm condition and the alarm generation is less than 5 seconds.
- If the AC power is disconnected and if the battery is discharged, the alarms settings are not modified and are stored indefinitely.

12.4 List of Alarms

12.4.1 Syringe Alarms

Message	Priority	Stops Infusion?	Problem / Resolution
Syringe installation !!!	High (!!!)	Yes	The syringe is not installed correctly (plunger driver, syringe barrel clasp or flange detection). ☞ Check the syringe installation.
Plunger head alarm !!!	High (!!!)	Yes	The plunger head is missing or incorrectly inserted. ☞ Check the syringe installation.
Disengagement mechanism !!!	High (!!!)	Yes	Disengaged mechanism. ☞ Check the syringe installation.
Remove completely syringe !	Low (!)	No	Preventive auto-test on potential failure of plunger head. ☞ Remove and reinstall the syringe.

12.4.2 Volume Limit Alarms

Message	Priority	Stops Infusion?	Problem / Resolution
End of volume limit !!!	High (!!!)	Yes	The volume limit is reached.
Near end of volume limit !!	Medium (!!)	No	The time remaining is less than the defined time duration (adjustable between 1 and 30 minutes), and the remaining VTBI until the volume limit has dropped to less than 10% of the syringe capacity.
End of volume limit !	Low (!)	No	The volume limit is reached and the end of infusion setting is set as "KVO" or "continuous".

12.4.3 Volume/Time & Dose/Time Alarms

Message	Priority	Stops Infusion?	Problem / Resolution
End of volume/time !!! End of dose/time !!!	High (!!!)	Yes	The VTBI is completed.
Near end of volume/time !! Near end of dose/time !!	Medium (!!)	No	The time remaining is less than the defined time duration (adjustable between 1 and 30 minutes), and the remaining VTBI has dropped to less than 10 % of the syringe capacity.
End of volume/time ! End of dose/time !	Low (!)	No	The VTBI is completed and the end of infusion setting is set as "KVO" or "continuous".

12.4.4 Infusion Alarms

Message	Priority	Stops Infusion?	Problem / Resolution
End of infusion !!!	High (!!!)	Yes	The infusion is completed (simple rate).
Near end of infusion !!	Medium (!!)	No	The time remaining is less than the defined time duration (adjustable between 1 and 30 minutes), and the remaining volume of fluid in the syringe has dropped to less than 10 % of the syringe capacity.
Check settings !!	Medium (!!)	No	The flow rate (or dose) has been modified using the keys, but has not been confirmed. ☞ Check the flow rate (or dose) and press OK to confirm.
Waiting settings !!	Medium (!!)	No	A value must be entered. ☞ Enter a value and press OK to confirm.

Message	Priority	Stops Infusion?	Problem / Resolution
Waiting start !!	Medium (!!)	No	The infusion settings have been entered, but have not been confirmed with start . ☞ Check the infusion settings, and press start to start the infusion.
Upper soft max	Information signal	No	The upper soft limit is exceeded, according to the drug settings defined in the drug library.
Lower soft min	Information signal	No	The lower soft limit is exceeded, according to the drug settings defined in the drug library.
Reached hard limit	Information signal	No	The upper or lower hard limit is reached.

12.4.5 Pressure Alarms

Message	Priority	Stops Infusion?	Problem / Resolution
Occlusion alarm !!!	High (!!!)	Yes	The pressure in the infusion line has reached the threshold level. ☞ Check whether the infusion line is occluded. If necessary, readjust the pressure threshold. See Section 8.3, page 67.
Occlusion pre alarm !!	Medium (!!)	No	In-line pressure has reached the following value: <ul style="list-style-type: none"> ▪ 25 mmHg / 2.5 kPa / 0.5 PSI below the programmed threshold (from 50 to 250 mmHg). ▪ 50 mmHg / 5 kPa / 1 PSI below the programmed threshold (over 250 mmHg). ☞ Check the infusion line. ☞ Set the correct pressure threshold.
Pressure increase !	Low (!)	No	The pressure is increasing in the infusion line. ☞ Check for occlusions in the infusion line.
Drop in pressure !	Low (!)	No	The pressure is decreasing in the infusion line. ☞ Check the downstream Luer lock connection and the integrity of the entire line.

12.4.6 Battery Alarms

Message	Priority	Stops Infusion?	Problem / Resolution
Battery alarm !!!	High (!!!)	Yes	The battery is discharged. ☞ The pump will power OFF automatically within 5 minutes. ☞ Connect the pump to a power supply immediately.
Very low battery !!!	High (!!!)	Yes	Very low battery. ☞ Connect the pump to a power supply and allow time to charge.
Battery pre alarm !!	Medium (!!)	No	Low battery. ☞ Connect the pump to a power supply.
	Low (!)	No	If the pump is not used during an extended period, connect to a power supply and wait until the battery is charged.

12.4.7 Power Alarms

Message	Priority	Stops Infusion?	Problem / Resolution
AC power failure !	Low (!)	No	The power supply is inconsistent. ☞ Contact your technical support.
Power disconnection	Information signal	No	The pump is disconnected from the AC power. A single beep is emitted. ☞ Press  to acknowledge. ☞ Check that the battery life is sufficient for the expected infusion duration. ☞ If the disconnection was unintentional, check the power connection.

12.4.8 Keypad Alarms

Message	Priority	Stops Infusion?	Problem / Resolution
Keypad lock status	Information signal	No	The keypad is locked. ☞ Unlock the keypad.
Keypad locked	Information signal	No	The keypad is locked and the syringe barrel clasp was opened and closed. ☞ Unlock the keypad.
Unlock keypad to continue			

12.4.9 Technical Error Alarms

Message	Priority	Stops Infusion?	Problem / Resolution
Erxx(yyyy) !!!	High (!!!)	Yes	Technical alarm. ☞ Contact your qualified technician or your Fresenius Kabi sales representative.
High internal temperature !	Low (!)	No	Temperature increase. ☞ Check device environment.
Alarm reporting not available on the Link !	Low (!)	No	The pump is mounted on a Link+ Agilia rack that has not been upgraded. ☞ Contact your qualified technician or your Fresenius Kabi sales representative.

In the case of a system malfunction, the alarm sounds and an error message Erxx(yyyy) !!! is displayed.

1. Record the error message Erxx(yyyy) !!!.
2. Disconnect the pump from the power supply.
3. Reset the device by pressing the  key for 10-15 seconds, and release it when the device powers off.



Warning

*If the alarms persist when the pump is powered on again, do not use the device on a patient, and contact qualified biomedical engineering staff in your healthcare facility, or your **Fresenius Kabi** sales representative.*

12.4.10 Audio-only Information Signals

Type	Comment	Stops Infusion?	Activation
Switch mode	Beep until key is released	No	Beep starts when action is not allowed
End of loading dose	3 beeps	No	At the end of the loading dose
End of programmed bolus	3 beeps	No	At the end of a programmed bolus
Start infusion at the end of pause	3 beeps	N/A	At the end of a pause, when the infusion automatically starts
AC power connection	1 beep	No	When power is connected
Forbidden key	1 beep	No	Repeated until key is released
Key beep	1 beep	No	For each key pressed
Other non validation beep	1 beep	No	For each key pressed
Manual bolus	1 beep	No	Repeated for each mL infused
Syringe prime	1 beep	N/A	Repeated every 5 seconds
End of pause	4 beeps	N/A	At the end of pause - repeated

13 Syringes

13.1 Syringe List

Information



- *Agilia SP pump offers a maximum 100 syringes of different types, brands and sizes. For a list of compatible syringes, and for ordering information, refer to the System Components booklet.*
- *The list of available syringes on your pump is accessible from the pump options.*
- *For general information on syringes (expiration date, storage, sterility, and so on), refer to the syringe manufacturer's instructions.*

Warning



- **Fresenius Kabi** cannot accept responsibility for any flow rate errors that are due to changes to syringe specifications introduced by the manufacturer.
- *Ensure syringe sizes and models are compatible with the syringe pump, refer to the System Components booklet. Use of incompatible syringes can cause injury to the patient and improper pump operation resulting in inaccurate fluid delivery, insufficient occlusion sensing, and other potential problems.*

13.2 Preparing a Syringe

1. Prepare the fluid to be infused according to your healthcare facility's protocol.
2. Select a syringe.
3. Check the syringe and access device integrity.
4. Connect the extension set to the syringe according to local practices.
5. If necessary, fill the syringe and check that it is watertight.
6. Manually prime the extension set according to your healthcare facility's protocol.
7. Confirm that there is no air in the syringe or in the extension set.

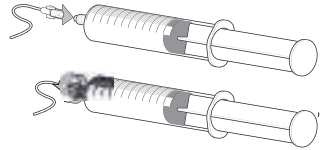

Information

- *The fluid in the syringe and the syringe must be within normal operating temperature conditions: +18 °/+30 °C.*
- *It is recommended to prime the set immediately before starting the infusion.*
- *Do not use in conjunction with positive pressure infusion devices that could generate back pressure higher than 2000 hPa (1500 mmHg): doing so will damage the administration set and the pump.*
- *Some extension sets may have components such as a filter that require special instructions.*
- *Certain drugs may require specific extension sets.*
- *Connect the infusion line in accordance with procedures in your healthcare facility using good medical practices. It is recommended to use a Luer lock system to reduce the risk of disconnection, leakage, air-in-line, or contamination.*
- *Manually prime the syringe and extension set to remove all air, before connecting to the pump.*



Precautions for the use of extension sets



- Use extension sets which have the smallest internal volume or “dead-space” to minimize residual volumes between the syringe and the patient when administering medications or fluids at low infusion rates (e.g., less than 5mL per hour, and especially flow rates less than 0.5 mL per hour). This reduces the amount of time it takes for fluid to reach the patient, maintains delivery accuracy, and reduces occlusion detection times.

For example:

- Tubing internal diameter: Small bore or microbore tubing is recommended when infusing at low rates
 - Tubing length: Tubing length should be minimized, when possible
 - Filters: Internal volume (dead-space) of in-line filters should be minimized
 - Connection sites: The number of connection sites such as stopcocks and Y-sites should be limited, and high risk or life-sustaining solutions should be connected as close to the intravenous access site as possible.
- Avoid use of extension sets with ports containing high pressure valves. High pressure valves require additional pressure (e.g., 50-200 mmHg) to open and allow fluid flow. These high pressure valves may cause a significant delay in therapy followed by a sudden bolus once the valve is opened, particularly at low infusion rates (e.g., less than 5 mL per hour, and especially flow rates less than 0.5 mL per hour).

13.3 Operations for Syringes

13.3.1 Removing a Syringe

1. Press  to stop the infusion.
2. Disconnect the patient.
3. Open the syringe barrel clasp.
4. Press  to silence the audible signal for 2 minutes.
5. Push the disengagement lever down and remove the syringe from its cradle.
6. Disconnect the syringe from its extension set.
7. Disconnect the extension set from the access device in accordance with healthcare facility protocol.

13.3.2 Changing a Syringe

1. Remove the syringe,
See section 13.3.1, page 106.
2. Prepare a new syringe and follow the steps described in the flowchart.
See section 6.1, page 31.
3. After the new syringe is installed, acknowledge the "same therapy" screen (optional screen).



Warning

Electronically prime the syringe pump system after replacing a near-empty syringe with a replacement syringe.



Information

Properly dispose of used syringes.

13.3.3 Syringe Replacement Interval

Replace the syringe according to your healthcare facility's protocol or CDC guidelines.

13.4 Gravity Infusion in Parallel with a Pump

You can infuse the contents of a fluid container via gravity, in parallel with the pump.

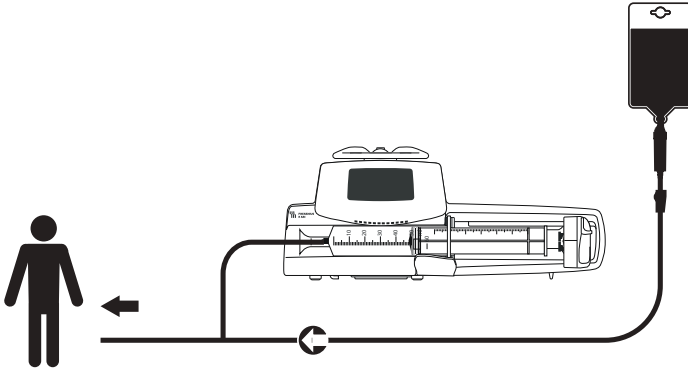

Figure 13.1: Gravity Infusion (in parallel with a pump)

Information

- **Fresenius Kabi** recommends the use of a back check valve or positive pressure infusion devices when an infusion on the pump is connected to a gravity line. This will prevent the back-up of IV fluid or medication into the gravity line.
- If there is no back check valve on a gravity infusion line during a multi-line infusion, it will be impossible to detect patient-side occlusions. Such an occlusion could cause the pumped drug to back up into the gravity line, and later be infused in an uncontrolled manner when the occlusion is released.
- Be careful about drugs interactions and incompatibilities during a multi-line infusion. **Fresenius Kabi** recommends infusing the critical drugs first.



14 Device Storage

14.1 Precautions for Storage

- Handle the device with care during storage.
- Store the device in a cool, dry place. The storage area must be clean and organized.
- Clean and disinfect the device prior to storage.

Warning



If the device is not used for an extended period (longer than 2 months), it is recommended that the battery be removed from the device and put in storage by authorized personnel. If the battery cannot be removed, or the device will be used in less than 2 months, charge the battery at least once a month by connecting the device to the AC power supply for at least 6 hours.

14.2 Storage and Transport Conditions

Observe the following conditions for storage and transport:

- Temperature:
-10 °C to +60 °C
- Pressure:
500 hPa (375 mmHg / 7.25 PSI) to 1060 hPa (795 mmHg / 15.37 PSI)
- Relative humidity:
10 % to 90 % without condensation
- Altitude:
Up to 3000 m

14.3 Preparing the Device for Storage

Prepare the device for storage as follows:

1. Power the pump OFF and remove the disposable.
2. If necessary (long-term storage), disconnect the pump's power cord and all data communication cables.
3. Remove the pump from its mounting point.
4. Clean the pump.
5. Handle the pump with care, and store it in a compliant area.

For detailed instructions, refer to the related chapters in this document.

14.4 Using the Device After Storage

The device can be used immediately after storage without any cooling or warm up period.

If the battery has been removed for long-term storage, contact your biomedical department in order to reinstall the battery prior to use.

We recommend charging the battery for at least 6 hours.

We recommend that the "User test" is performed when the device is installed after storage, and before being used on a patient, see section 11, page 95.

15 Specifications

Information



The range of settings and default values described in this section correspond to the factory configuration. Range of settings and default values may be adjusted in the pump options (Basic Profile) or in Agilia Vigilant Drug'Lib software (custom profiles). Increment rules may be modified by Agilia Vigilant Drug'Lib software (custom profiles).

15.1 Essential Features

The pump's essential features are defined in standard operating conditions:

Feature	Refer to
Flow Rate Accuracy	Section 15.9.1, page 114. Section 18.9, page 127.
Time to Detect Occlusion	Section 15.9.3, page 114.
Bolus Volume After Occlusion Release	Section 15.9.4, page 115.
Management of High-priority Alarms	Section 12, page 99.

15.2 Flow Rate

	Format	Syringe					Minimum Increment	
		50 mL / 60 mL	30 mL	20 mL	10 mL	5 mL		
Infusion Rate	mL/h	0.1 → 1200	0.1 → 600	0.1 → 600	0.1 → 350	0.1 → 250	0.01 0.1 1	(0.10 → 9.99) (10.0 → 99.9) (100 → 1200)
Direct Bolus*	mL/h	50 → 1200	50 → 600	50 → 600	50 → 350	50 → 250		50
Priming	mL/h	1200	600	600	350	250		N/A
Programmed Bolus	mL/h	0.1 → 1200	0.1 → 600	0.1 → 600	0.1 → 350	0.1 → 250	0.01 0.1 1	(0.10 → 9.99) (10.0 → 99.9) (100 → 1200)
KVO**	mL/h	0.1 → 5	0.1 → 5	0.1 → 5	0.1 → 5	0.1 → 5		0.1
Loading Dose	mL/h	0.1 → 1200	0.1 → 600	0.1 → 600	0.1 → 350	0.1 → 250	0.01 0.1 1	(0.10 → 9.99) (10.0 → 99.9) (100 → 1200)

* Direct bolus default value = Upper flow rate value for each syringe size.

** KVO default value = 1 mL/h.

15.3 Volume To Be Infused (VTBI)

	Format	Range of Settings	Default Value	Minimum Increment
Volume Limit	mL	0.1 → 999	0.1	0.1 1 (0.1 → 99.9) (100 → 999)
Volume/Time	mL	0.1 → 99.9	0.1	0.1
Direct Bolus	mL	0.1 → 50	N/A	0.1
Programmed Bolus	mL	0.1 → 99.9	0.1	0.1

Applicable for all syringe sizes (50/60 mL, 30 mL, 20 mL, 10 mL, 5 mL)

15.4 Dose To Be Infused (DTBI)

	Format	Range of Settings	Default Value	Minimum Increment
Dose	Unit	0.01 → 9999	N/A	0.001 (0.010 → 4.999) 0.01 (5.00 → 9.99) 0.1 (10.0 → 99.9) 1 (100 → 9999)
Programmed Bolus	Unit	0.01 → 9999	N/A	0.01 (0.01 → 9.99) 0.1 (10 → 99.9) 1 (100 → 9999)
Loading Dose	Unit	0.01 → 9999	N/A	0.01 (0.01 → 9.99) 0.1 (10.0 → 99.9) 1 (100 → 9999)

Applicable for all syringe sizes (50/60 mL, 30 mL, 20 mL, 10 mL, 5 mL)

15.5 Infusion Time

	Format	Range of Settings	Default Value	Minimum Increment
Infusion Rate	__ h __ min __	00h00min01 → 96h00min00	N/A	00h00min01
Programmed Bolus	__ h __ min __	00h00min01 → 24h00min00	00h02min00	00h00min01
Loading Dose	__ h __ min __	00h00min01 → 24h00min00	00h02min00	00h00min01
KVO Silence Alarm Duration	__ h __	00h01 → 12h00	00h01	00h01
Pause	__ h __	00h01 → 24h00	00h01	00h01

Applicable for all syringe sizes (50/60 mL, 30 mL, 20 mL, 10 mL, 5 mL)

15.6 Concentration

	Format	Range of Settings	Default Value	Minimum Increment
Concentration	Unit	0.01 → 70000	0.01	0.01 (0.01 → 9.99) 0.1 (10.0 → 99.9) 1 (100 → 70000)
Volume of Diluent	mL	1 → 2000	1	1

Applicable for all syringe sizes (50/60 mL, 30 mL, 20 mL, 10 mL, 5 mL)

15.7 Patient Data

	Format	Range of Settings	Default Value	Minimum Increment
Patient Weight	kg	0.25 → 350	70	0.01 0.1 1 (0.25 → 9.99) (10.0 → 19.9) (20 → 350)
Patient Body Surface Area	m ²	0.05 → 4.5	2	0.01

15.8 Pressure Management

	Setting Description	Setting Format	Default Value
Mode	Infusion pressure mode.	3 levels / Variable	Variable
DPS	Allows DPS option activation on the pump pressure menu.	Yes / No	Yes
Unit	Pressure unit selection.	mmHg / kPa / PSI	mmHg
Limit Stored	The last pressure limit adjustment is automatically stored in memory for the next startup.	Enabled / Disabled	Disabled
DPS Stored	The last DPS adjustment is automatically stored in memory for the next startup.	Enabled / Disabled	Disabled

		Format	Range of Settings	Default Value	Minimum Increment
3 Levels	Low	mmHg	50 → 300	100	50
	Medium	mmHg	150 → 600	250	50
	High	mmHg	250 → 900	500	50
Variable	Full Range	mmHg	50 → 900	500	25 50 (50 → 250) (250 → 900)
	Maximum Limit	mmHg	500 → 900	900	50
DPS	Raise Threshold	mmHg	50 → 400	100	50
	Drop Threshold	mmHg	100 → 400	100	50

Note: 1 bar = 750 mmHg = 100 kPa = 14.5 PSI.

15.9 Accuracy



Warning

Accuracy (flow rate, time, volume infused, pressure) can be influenced by syringe model, syringe configuration, extension set configuration, fluid viscosity, and fluid temperature.

Note: All tests below are in accordance with the IEC 60601-2-24 standard and ANSI/AAMI ID26.

Values are representative of syringes used during internal tests and are provided as indicators only.

15.9.1 Flow Rate Accuracy

	Accuracy
Flow Rate	± 3%

15.9.2 Effects of Pressure Variations on Accuracy

Back Pressure	Accuracy (From Mean Values)
+ 39.9 kPa	~ - 3%
+ 13.33 kPa	~ - 1.5%
- 13.33 kPa	~ + 1.5%

15.9.3 Occlusion Alarm Accuracy

Occlusion Alarm Response Time*	Accuracy			
	Syringe**	Rate	Occlusion Alarm Threshold	
			50 mmHg	900 mmHg
	50 mL	0.1 mL/h	< 5 hours	< 28 hours
		1 mL/h	< 30 minutes	< 3 hours
		5 mL/h	< 7 minutes	< 30 minutes
	20 mL	0.1 mL/h	< 4 hours	< 14 hours
		1 mL/h	< 20 minutes	< 75 minutes
		5 mL/h	< 5 minutes	< 15 minutes

* Test condition: Temperature: 20 °C, Extension set length: 150 cm

** Syringe: BD Precise

15.9.4 Volume Accuracy



Warning

Accuracy may be reduced when the infusion flow rate is below 1 mL/h.

		Accuracy			
Direct Bolus*		≤ 10 mL: ± 0.2 mL			
Programmed Bolus*		> 10 mL: ± 3%			
Bolus Volume at Occlusion Release*		Bolus Volume at Occlusion Release			
		Syringe**	Rate	50 mmHg	900 mmHg
	50 mL	5 mL/h	-0.05 ≤ X ≤ 0.35 mL	-0.05 ≤ X ≤ 0.35 mL	

* Test condition: Back pressure: 0 mmHg

** Syringe: BD Precise

- A back flow pumping is provided to reduce the bolus volume at occlusion release.
- During pump movement from 0 to 1 m above the patient, a bolus ($-0.05 \leq X \leq 0.35$ mL) may occur.

15.9.5 Pressure Accuracy

		Accuracy	
Pressure		< 500 mmHg: ± 75 mmHg	> 500 mmHg: ± 15 %

15.10 Units and Conversion Rules

15.10.1 Concentration Units

	Units	Suffix
Concentration Units	nanog, microg, mg, g	/mL, /--mL
	mmol	
	mUnit, Unit	
	cal, kcal	
	mEq	

15.10.2 Dose Units

	Units
Dose Units	nanog/h, nanog/kg/min, nanog/kg/h
	microg/min, microg/h, microg/kg/min, microg/kg/h
	mg/min, mg/h, mg/24h, mg/kg/min, mg/kg/h, mg/kg/24h, mg/m ² /h, mg/m ² /24h
	g/h, g/kg/min, g/kg/h, g/kg/24h
	mmol/h, mmol/kg/h, mmol/kg/24h
	mUnit/min, mUnit/kg/min, mUnit/kg/h
	Unit/min, Unit/h, Unit/kg/min, Unit/kg/h
	kcal/h, kcal/24h, kcal/kg/h
	mEq/min, mEq/h, mEq/kg/min, mEq/kg/h
	mL/kg/min, mL/kg/h, mL/kg/24h

15.10.3 Conversion Rules

Conversion Rules	1 micro unit = 1000 nano unit	
	1 m unit = 1000 micro unit	
	1 k unit = 1000 unit	
	1 unit/h = 24 unit/24 h	
	1 unit/min = 60 unit/h	
	$\text{mL/h} = \frac{\text{unit/kg/h (dose)} \times \text{kg (weight)}}{\text{unit/mL (concentration)}}$	Conversion of a dose including the unit/kg into volume flow rate (mL/h)
	$\text{mL/h} = \frac{\text{unit/m}^2/\text{h (dose)} \times \text{m}^2 \text{ (body surface area)}}{\text{unit/mL (concentration)}}$	Conversion of a dose including the unit/m ² into volume flow rate (mL/h)
	$\text{mL/h} = \frac{\text{unit/h (dose)}}{\text{unit/mL (concentration)}}$	Expression of a volumetric flow rate
$\text{mL} = \frac{\text{unit/kg (dose)} \times \text{kg (weight)}}{\text{unit/mL (concentration)}}$	Conversion of a dose including the unit/kg into volume (mL)	
$\text{mL} = \frac{\text{unit/m}^2 \text{ (dose)} \times \text{m}^2 \text{ (body surface area)}}{\text{unit/mL (concentration)}}$	Conversion of a dose including the unit/m ² into volume (mL)	
$\text{mL} = \frac{\text{unit (dose)}}{\text{unit/mL (concentration)}}$	Expression of a volume (mL)	

16 Cleaning and Disinfecting

To avoid the risks of infection and microbial transmission, make sure to adequately clean and disinfect the equipment.

Warning



- *The disinfecting procedure must be done immediately after cleaning. Disinfecting the pump without prior cleaning is not effective.*
- *The pump is not intended to be sterilized; sterilization may result in damage to the pump.*
- *In case of contamination by blood or bodily fluids when the pump is in use, and if allowed by your local practices and healthcare facility policies, immediately perform the quick cleaning described below. Always follow your local protection rules.*

Quick Cleaning Only

Note: This quick cleaning does not replace the need for a complete cleaning.

1. Check that the keypad is locked in order to avoid unintended modification of the infusion parameters. Do not move the pump.
2. Use ready-to-use wipes to wipe down all exposed surfaces of the pump.
3. At the end of the infusion, perform the complete cleaning protocol, see section 16.3.1, page 120.

16.1 When to Clean and Disinfect the Pump

Thoroughly clean and disinfect the pump in the following cases:

- After each patient use
- Before any maintenance
- On a routine basis when the pump is not in use
- Before storage

16.2 Recommended and Prohibited Agents

We recommend the following cleaning and disinfecting agents:

16.2.1 Recommended Agents

	Recommended Agent
Cleaning	Didecyldimethylammonium chloride (example: Wip'Anios Excel by Anios)
Disinfecting	Didecyldimethylammonium chloride (example: Wip'Anios Excel by Anios)

16.2.2 Prohibited Agents

The following cleaning and disinfecting agents are prohibited:

- Trichloroethylene
- Abrasive detergents
- Undiluted alcohol

These aggressive agents may damage the plastic parts of the pump and cause it to malfunction.

16.3 Instructions for Cleaning and Disinfecting

Follow the instructions provided to ensure effective cleaning and disinfecting of the equipment.

- Use the agents according to the manufacturer's instructions. This may include wearing personal protective equipment (gloves, lab coat, glasses, and so on), or diluting the agent according to the manufacturer's guidelines.
- For disinfectants, respect the contact time required for the antimicrobial agents to act (the time the agent must be left on the pump for disinfection to be effective).

The following warning is provided to protect staff against electric shock, and to protect the pump from damage that can cause it to malfunction.

Warning



- *Only trained staff can clean and disinfect the pump.*
- *Do not place the pump in an autoclave or immerse it in liquid.*
- *Do not spray liquids directly on connectors. Instead, use a cleaning cloth or disposable wipes.*

16.3.1 Cleaning Instructions

Prerequisites

- The pump is powered off.
- The power cord and all other cables are unplugged.
- The air is at room temperature (20 to 25 °C).
- The operator is wearing suitable protective equipment.

Protocol

1. Place the pump on a clean surface or disposable underlay.
2. Use a ready-to-use wipe to remove any major grime.
3. Thoroughly wipe down all exposed surfaces (housing, keyboard, syringe barrel area, syringe guard, plunger driver, disengagement lever, syringe barrel clasp, etc.) of the pump, from top to bottom. You can use the silver handle to lift and move the pump.
 - *When wiping down the sides, avoid wetting the connector sockets.*
 - *Do not allow liquids to run, leak, or drip into the pump housing.*
4. Make sure the pump remains damp for at least 1 minute.
5. Set down the pump, and wipe down the silver handle, the attachment lock knob, the screw clamp and the release button.
6. Use a fresh ready-to-use wipe to gently wipe down the back side of the syringe barrel clasp and all exposed surfaces in the syringe barrel area.
7. Make sure the pump remains damp for at least 1 minute to dissolve all organic matter.
8. Use a swab to gently scrub the exposed surfaces of the pump. Be sure to scrub along the seams and edges of the control panel, and the narrow or hard-to-reach areas.
9. Wipe down the power cord and any pump accessories.
10. Allow the pump to dry completely at room temperature.

16.3.2 Disinfecting Instructions

Prerequisites

- The cleaning protocol has been performed.
- The pump is powered off.
- The power cord and all other cables are unplugged.
- The air is at room temperature (20 to 25 °C).
- The operator is wearing suitable protective equipment.

Protocol

1. Place the previously cleaned pump on a clean surface or disposable underlay.
2. Use a ready-to-use wipe to wipe down all exposed surfaces of the pump, making sure to cover all cracks, crevices, and hard-to-reach areas. You can use the silver handle to lift and move the pump.
 - *When wiping down the sides, avoid wetting the connector sockets.*
 - *Do not allow liquids to run, leak, or drip into the pump housing.*
3. Set down the pump, and wipe down the silver handle, the attachment lock knob, the screw clamp and the release button.
4. Use a fresh ready-to-use wipe to gently wipe down the back side of the syringe barrel clasp and all exposed surfaces in the syringe barrel area.
5. Using a fresh ready-to-use wipe, repeat steps 2 to 4.
6. Leave the disinfecting agent on the pump for at least 3 minutes.
7. Wipe down the power cord and any pump accessories.
8. Allow the pump to dry completely at room temperature.

17 Power Management

17.1 AC Power Supply Precautions

Check that the AC power supply voltage corresponds to the value indicated on the label on the bottom of the device. Do not exceed the permitted voltage.

The power outlet must remain accessible at all times to allow emergency power supply disconnection.

Warning



- *The pump and its accessories can only be connected to the AC power supply with the power cord supplied by **Fresenius Kabi**, or with a power supply accessory from the Agilia product range.*
- *Do not use an extension cord when connecting the pump to the AC power supply.*
- *Pumps must be plugged into a medical grade power strip if one is used.*

17.2 Battery Precautions

The device uses a Lithium-ion rechargeable battery.

The following actions may cause leakage, overheating, smoke, explosion or fire; which could result in deterioration of performance, failure, damage to the equipment or injury to the user:

- Incorrect handling of a Lithium-ion battery.
- Replacement of the battery by inadequately trained personnel.

Information

- *Do not replace with a battery other than the one provided by **Fresenius Kabi**.*
- *Do not use the pump without the battery connected.*
- *Do not disconnect the battery when the device is operating on AC or battery power. Disconnect the power cord and power off the device before disconnecting the battery.*
- *Do not incinerate or place near a flame.*
- *Do not drop, crush, puncture, modify or disassemble the battery.*
- *Do not use a battery that is severely scratched or damaged.*
- *Do not short the terminals.*
- *Do not expose to high temperatures or very low temperatures: refer to the operating conditions for use, and the storage instructions.*
- *Do not try to charge or discharge the battery outside of the device.*
- *For more information on replacing the battery, refer to the technical manual.*



17.3 Battery Operating Mode

The device is provided with an internal battery that automatically provides power to the device in case of power failure or disconnection from the AC power supply. The battery charges when the pump is connected to AC power supply.

Before starting for the first time, charge the battery for approximately 6 hours by plugging in the power supply cord with the pump powered off.

Information

During operation, leave the device connected to the power supply in order to maintain the battery's charge and maximum capacity, and to maximize battery lifetime and performance.



18 Technical Characteristics

18.1 Power Supply

It is mandatory to use an Agilia power cord compliant with USA standards and with the IEC 60227 standard.

The power cord conductor must have a cross section of at least 0.75 mm².

AC Power	 Power supply	100 V - 240 V ~ / 50 / 60 Hz with functional earth
	Maximum consumption	10-15 VA
	Protective fuse	1 X T1.6AH 250V accessible in the battery compartment

18.2 Battery

Disconnect the battery before opening the device. Avoid short circuits and extreme temperatures.

If the device is not used for more than 3 months, the date is erased (all other settings are stored permanently). When you power on the pump, you must set the date again.

Characteristics	7.2 V 2.2 Ah - Li-ion Smart battery		
Weight	Approximately 100 g		
Battery Life	Flow Rate	Wi-Fi	Battery Life
	5 mL/h	✓	> 9 h
	5 mL/h	✗	> 13 h
Battery Recharge	Pump OFF: < 6 h / Pump ON: < 20 h		

✓ = Wi-Fi enabled



✗ = Wi-Fi disabled or not used

18.3 Power Consumption

The pump typically consumes about 3.5 W in standard operating conditions.

18.4 Communication Port

The connector located at the back of the device allows data communication with a PC.

Serial Cable	TTL output
Power Input	 10 V / 15 W to power supply the product
Power Output	 5 VDC / 150 mA to power Agilia USB cable

18.5 Infrared Communication

The pump is equipped with an infrared cell located at the back of the device.

Mode	Wireless optical communication using infrared light
Compatibility	Asynchronous Serial Infrared (SIR) physical layer irPHY 1.0, baseband no carrier
Transport Protocol	Proprietary
Speed	115.2 kb/s max
Wavelength	880 nm to 900 nm infrared band with 45 nm spectral bandwidth
Eye Safety	Class 0 of IEC 62471

18.6 Sound Levels

18.6.1 Operating Pump Sound Levels (without alarms)



Flow Rate (mL/h)	Sound Level (dBA)
0	21
1	23
20	27
100	30
400	49
1200	32

Note: These values are provided for information purposes only.

18.6.2 Alarms Sound Levels

Alarm Priority	Sound Level (dBA)	
	min	Max
High-priority	55	63
Medium-priority	50	57
Low-priority	45	52

18.7 Compliance

ElectroMedical Equipment Safety	Compliant with the following standards: <ul style="list-style-type: none"> IEC 60601-1 IEC 60601-1-8 	IP22 Index of protection against ingress of water or particulate matter
EMC (ElectroMagnetic Compatibility)	Compliant with the following standard: <ul style="list-style-type: none"> IEC 60601-1-2 	 Protection against leakage current: Defibrillation-proof type CF applied part*
Particular Standards	<ul style="list-style-type: none"> IEC 60601-2-24 ANSI/AAMI ID26 	 Protection against electric shocks: class II  Functional earth**

* After a defibrillation, the pump recovery time is around 2 seconds.

** The functional earth is directly connected to the power supply cord. It reduces residual current that may disturb ECG or EEG devices.

18.8 Dimensions and Weight

H / W / D	135 x 345 x 170 mm
Weight	Approximately 2.1 kg
Screen Size	70 x 35 mm

18.9 Trumpet and Start-up Curves

The trumpet curve shows the variation of the mean flow rate accuracy over specific observation periods. The variations are presented only as maximum and minimum deviations from the overall mean flow within the observation window.

Trumpet curves are presented below for a number of representative flow rates.

The test protocol used to obtain these results is described in ANSI/AAMI ID26.

The curves can be helpful in determining the suitability of infusion parameters for specific drugs and concentrations.

Syringe used: BD Precise 50 mL

Fluid used: distilled water

Recommendations to improve performances and safety when the pump is commonly used at low flow rates (≤ 20 mL/h):

- Limit the range of available flow rates in accordance with the maximum flow rate to be used.
- Lower the pressure limit in order to gain in time to detect occlusion.

18.9.1 Flow rate: 1 mL/h

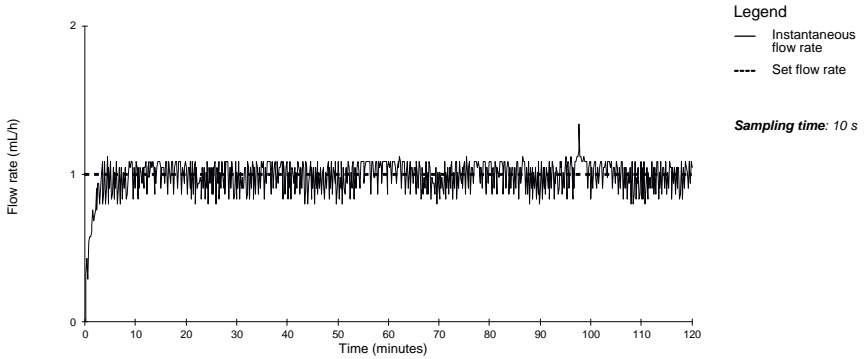

Figure 18.1: Start-up and instantaneous flow rate (1 mL/h over first 2 hours on 96 hours)

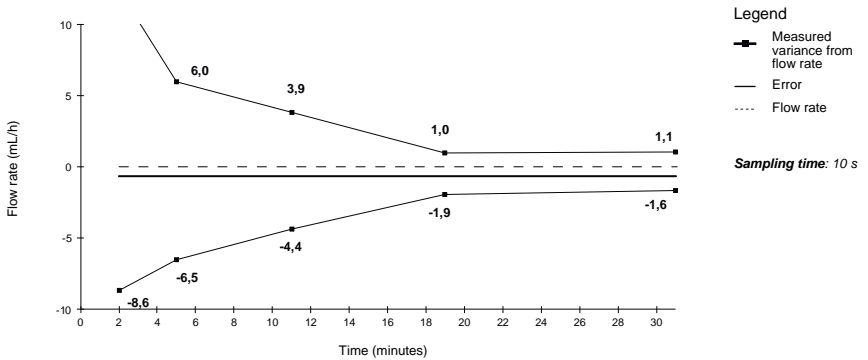

Figure 18.2: Trumpet curves for 2, 5, 11, 19, 31 minutes observation windows (1 mL/h over first 2 hours on 96 hours)

18.9.2 Flow rate: 5 mL/h

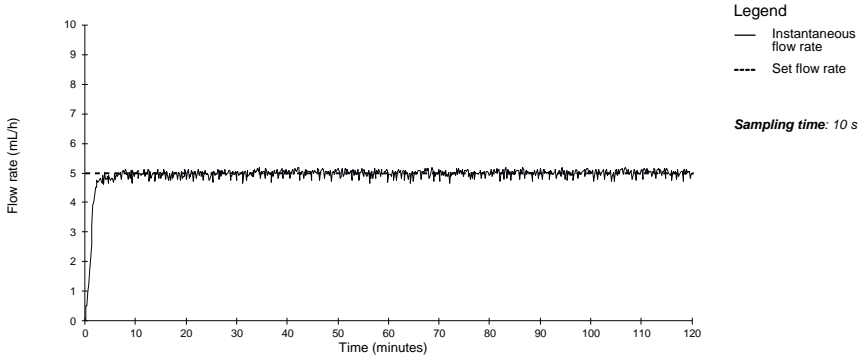

Figure 18.3: Start-up and instantaneous flow rate (5 mL/h over first 2 hours on 96 hours)

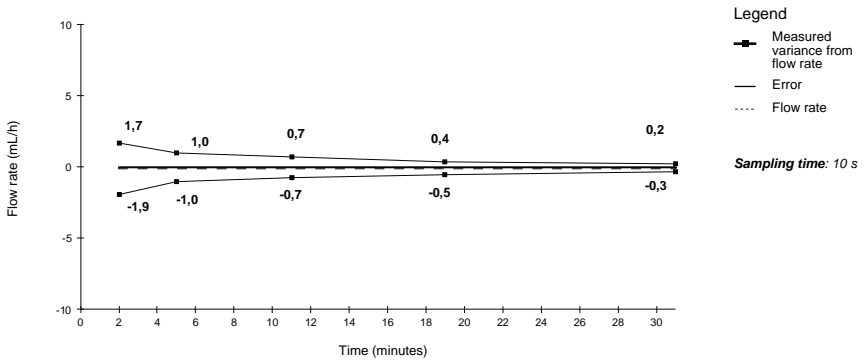

Figure 18.4: Trumpet curves for 2, 5, 11, 19, 31 minutes observation windows (5 mL/h over first 2 hours on 96 hours)

19 Wi-Fi

19.1 General Information

The Agilia Connect Infusion System includes an IEEE 802.11 radio-frequency transmitter incorporated in the Agilia Wi-Fi pumps. It operates using the following standards and frequencies:

- IEEE 802.11a: 5 GHz Frequency Band
- IEEE 802.11b: 2.4 GHz Frequency Band
- IEEE 802.11g: 2.4 GHz Frequency Band
- IEEE 802.11n: 2.4 and 5 GHz Frequency Band



Information

For more information on differentiation between Wi-Fi and non Wi-Fi pumps, see section 10.3, page 93.

The Wi-Fi module incorporated in the Agilia Wi-Fi pumps is intended to perform the following, via periodic communication cycles:

- Transfer data sets (from Centerium server to pump)
- Transfer pump history (from pump to a server)
- Communicate general information on the operating status of the pump

Agilia infusion pumps contain transmitter with the following IDs:

- FCC ID: XF6-RSWC301
- IC ID: 8407A-RSWC301.

Agilia Wi-Fi pumps must be installed to provide a separation distance of at least 8 in (20 cm) from all persons and must not be co-located or operating in conjunction with any other antenna or transmitter.



Warning

Agilia Wi-Fi pumps must be configured by qualified and appropriately trained staff.



Information

*If communication with the wireless network is interrupted, the pump can be used as intended. For more information, contact your **Fresenius Kabi** sales representative*

19.2 Specifications

19.2.1 Technical Specifications

	Description
Technology	IEEE 802.11 a/b/g/n
Frequency Band	<ul style="list-style-type: none">▪ 2.400 → 2.500 GHz (2.4 GHz is ISM band)▪ 4.900 → 5.850 GHz (High Band)
Modulation	OFDM with BPSK, QPSK, 16-QAM, and 64-QAM 802.11b with CCK and DSSS
Wireless Security	WPA/WPA2-Enterprise, WPA/WPA2-PSK
Network Protocols	TCP, IPv4, DHCP, HTTP
Typical Transmit Power (± 2 dBm)	<ul style="list-style-type: none">▪ 17 dBm for 802.11b DSSS▪ 17 dBm for 802.11b CCK▪ 15 dBm for 802.11g/n OFDM▪ 12 dBm in 802.11a mode

19.2.2 Electromagnetic Compatibility

For information on electromagnetic compatibility, see section 23.2.3, page 174.

19.2.2.1 USA - FCC Notice

The users manual or instruction manual for an intentional or unintentional radiator shall caution the user that changes or modifications not expressly approved by the party responsible for compliance could void the user's authority to operate the equipment.

19.2.2.2 Europe - R&TTE Directive

This product is designated as a radio device that utilizes harmonized frequencies and power levels for Europe.

19.2.3 Protocols and Standards

This wireless functionality references and uses the following protocols and standards:

- IEEE 802.11a/b/g/n standard
- WPA/WPA2-Enterprise, WPA/WPA2-PSK (Wi-Fi protected access) is a long-term security solution for wireless networks. For more information, refer to the IEEE 802.11.
- TCP (Transmission Control Protocol / Internet Protocol), IPv4 (Internet Protocol Version 4), DHCP (Dynamic Host Configuration Protocol) and HTTP (Hypertext Transfer Protocol) are standard data transport protocols used for the internet and other similar networks.

Agilia infusion pumps do not require an active wireless communication to function as intended (infuse). All wireless transactions are initiated by the device and are periodic in nature. The absence of connection (for example, out of range) does not affect the device ability to infuse. Data that is pending is stored and re-transmitted when the connection becomes available. Data integrity and quality of service are inherent in the design. The system should be ensured and maintained by a qualified and trained technical user, or a **Fresenius Kabi** representative.

20 Troubleshooting

Issue	Recommended Actions
The pump is unstable when mounted.	<ul style="list-style-type: none"> ▪ Check that the rotating pole clamp is fastened.
The pump is damaged, or you notice something abnormal (unusual noise, abnormal heat or smoke).	<ul style="list-style-type: none"> ▪ Remove the power cord. ▪ Contact your biomedical department or your Fresenius Kabi sales representative immediately.
The pump has been dropped or was subjected to a force that may have produced internal damage.	<ul style="list-style-type: none"> ▪ Do not use the pump. ▪ Contact your biomedical department or your Fresenius Kabi sales representative.
The pump cannot be installed or removed from the Link Agilia.	<ul style="list-style-type: none"> ▪ Check the rotating pole clamp position. ▪ Contact your biomedical department or your Fresenius Kabi sales representative.
The pump does not start after pressing  .	<ul style="list-style-type: none"> ▪ Connect the pump to the AC power supply to see if the battery is fully discharged. ▪ Contact your biomedical department or your Fresenius Kabi sales representative.
Data communication cables cannot be connected or removed from the pump.	<ul style="list-style-type: none"> ▪ Check the cable connector. ▪ Check the pump connector. ▪ Contact your biomedical department or your Fresenius Kabi sales representative.
Flow rate variance is higher than flow rate accuracy.	<ul style="list-style-type: none"> ▪ Check the infusion line configuration. ▪ Check the fluid viscosity. ▪ Check that the fluid temperature is within the recommended range. ▪ Contact your biomedical department or your Fresenius Kabi sales representative.
Keypad problem (keys, LEDs).	<ul style="list-style-type: none"> ▪ Check the general condition of the keypad. ▪ Check the contrast. ▪ Contact your biomedical department or your Fresenius Kabi sales representative.
The power supply indicator does not light up.	<ul style="list-style-type: none"> ▪ Connect the pump to the AC power supply. ▪ Contact your biomedical department or your Fresenius Kabi sales representative.
The pump powers off on its own.	<ul style="list-style-type: none"> ▪ Connect the pump to the AC power supply. ▪ Contact your biomedical department or your Fresenius Kabi sales representative.
The battery alarm is ON even though the pump has been correctly charged.	<ul style="list-style-type: none"> ▪ Check the AC power voltage. ▪ Contact your biomedical department or your Fresenius Kabi sales representative.
The pump powers off when it is disconnected from the AC power supply.	<ul style="list-style-type: none"> ▪ The battery is completely discharged: charge the battery. ▪ Contact your biomedical department or your Fresenius Kabi sales representative.
Wi-Fi communication error.	<ul style="list-style-type: none"> ▪ Contact your IT or biomedical department, or your Fresenius Kabi sales representative.

Issue	Recommended Actions
At start-up, the pump displays: "Software is upgrading...".	<ul style="list-style-type: none"><li data-bbox="460 148 1030 225">▪ Connect the pump to the AC power supply. Then, wait few minutes without touching the keypad until the message disappears and the pump starts as usual.<li data-bbox="460 228 1030 276">▪ Contact your biomedical department, or your Fresenius Kabi sales representative.

21 Recycling



Before disposal, remove the battery from the device. Batteries and devices with this label must not be disposed of with the general waste. They must be collected separately and disposed of according to local regulations.

Information



- For more information on waste processing regulations, contact your **Fresenius Kabi** sales representative or the local distributor.
- For more information on dismantling the device, refer to the technical manual.
- Follow healthcare facility policy regarding proper disposal after use.

22 Warranty

22.1 General Warranty Conditions

Fresenius Kabi guarantees that this product is free from defects in material and workmanship during the period defined by the accepted sales conditions, except for the batteries and the accessories.

22.2 Limited Warranty

To benefit from the materials and workmanship guarantee from our **Fresenius Kabi** sales representative or authorized agent, make sure to observe the following conditions:

- The device must have been used according to the instructions described in this document and in other accompanying documents.
- The device must not have been damaged while being stored or repaired, and must not show signs of improper handling.
- The device must not have been altered or repaired by unqualified personnel.
- The internal battery of the device must not have been replaced by a battery other than that specified by the manufacturer.
- The serial number (SN) must not have been altered, changed or erased.

Information



- *If one or more of these conditions have been violated, **Fresenius Kabi** will prepare a repair estimate covering all required parts and labor.*
- *To repair or return a device, contact your **Fresenius Kabi** sales representative.*

22.3 Warranty Conditions for Accessories

Batteries and accessories may have specific warranty conditions.

Contact your **Fresenius Kabi** sales representative for more information.

23 Guidance and Manufacturer's Declaration on EMC

23.1 Electromagnetic Compatibility

Warning



- *Agilia pump and its accessories are intended to be used in the electromagnetic environments specified below.*
- *The customer or the user of Agilia pump should ensure that it is used in such environments.*
- *Agilia pump must not be used in the presence of intense electromagnetic fields, such as those generated by certain electrically powered medical devices. Do not use the pump in MRI.*
- *Prolonged exposure to X-ray environments can damage the electronic components of the device and influence the flow rate accuracy. For a safe usage, we recommend to:*
 - *always put the device at the maximum distance from the patient and the source*
 - *limit the presence of the device in such environments.*

When mounted on the Link+ Agilia, the pump is intended to be used in the electromagnetic environment specified in the Link+ Agilia IFU.

Excluding the cases described in this manual, pump operation must be systematically checked by a qualified operator, if the pump is installed in the vicinity of other electrical devices.

Points (e.g. screws) and surfaces that are only accessible for maintenance also require precautions. Points (e.g. battery contacts for battery replacement) and surfaces that are accessible only by maintenance staff also require precautions.

23.2 Electrostatic Discharge (ESD)

Information

- *Electronic components and semiconductors can be destroyed by electrostatic discharge (ESD). In particular, components made with metal oxide semiconductor (MOS) can be damaged from direct or indirect discharges. Damage caused by ESD may not be immediately identifiable, and malfunctions can even occur after a longer period of operation.*
- *Exceeding and / or repeating the test level attained in guidance & manufacturer's declaration on EMC may permanently damage the device and / or cause serious malfunctions (for example, loss of communication and system failures).*

The following environmental conditions related to electrostatic sensitive components (ESD standards) must be observed:

- Floors coated with wood, tiles or concrete
- Relative humidity of at least 30%

If it is not possible to guarantee this environment, the following additional precautions must be taken:

- Use of anti-static equipment
- Preliminary user discharge (explained below)
- Anti-static clothing

The best precaution is preliminary user discharge on a grounded metal object such as a rail, a pole or a metal part located at the rear of Agilia pump.

For maintenance operation performed on Agilia pump, place the device on a conductive working surface, and wear a special ESD conductive wristband.

23.3 Electromagnetic Compatibility and Interference Guidance

Agilia pump has been tested in accordance with the electromagnetic compatibility standards applicable to medical devices. Its immunity is designed to ensure correct operation. Limitation of the emitted radiation avoids undesirable interference with other equipment.

Agilia pump is classified as a Class B device according to CISPR 11 emitted radiation. The user might be required to take mitigation measures, such as relocating or reorienting the equipment.



Warning



- *Use of the Agilia pump adjacent to or stacked with other equipment should be avoided because it could result in improper operation. If such use is necessary, this equipment and the other equipment should be observed to verify that they are operating normally.*
- *Use of accessories, transducers and cables other than those specified or provided by the manufacturer of the Agilia pump could result in increased electromagnetic emissions or decreased electromagnetic immunity of this equipment and result in improper operation.*
- *Portable RF communications equipment (including peripherals such as antenna cables, internal and external antennas) should be used no closer than 10 cm for cell phones and 30 cm for other equipments, to any part of the Agilia pump, including cables specified by the manufacturer. Otherwise, degradation of the essential performances of Agilia pump could result.*
- *Electrosurgical equipment (including base unit, cables, electrodes) should be used no closer than 30 cm, to any part of the Agilia pump, including cables specified by the manufacturer. Otherwise, degradation of the essential performances of Agilia pump could result.*

The user might be required to take mitigation measures, such as relocating or re-orienting the equipment.

If the Agilia pump is placed near RF communication equipment such as cell phones, DECT phones or wireless access points, RFID reader & tags,... It is essential to observe a minimum distance between the Agilia pump and this equipment specified above. If the Agilia pump causes harmful interference or if it is itself disrupted, the user is encouraged to try to correct the interference by one of the following actions:

- Reorient or relocate the Agilia pump, the patient or disruptive equipment.
- Change the routing of cables.
- Connect the Agilia pump power plug to a protected / backed-up / filtered supply or directly to the UPS circuit (uninterruptible power supply).
- Increase the separation between the Agilia pump and disruptive equipment.
- Plug the Agilia pump into an outlet on a different circuit from the one to which the patient or disruptive equipment is connected.
- In any case, whatever the context, the user should conduct interoperability testing in a real situation to find the correct setup and location.

23.4 EMC and essential performances

In the case of electromagnetic disturbances, if the essential performance, Section 15.1, page 139, is lost or degraded, the consequences for the patient are as follows: overdose, underdose, delay of therapy, air embolism, trauma, exsanguination.

23.4.1 Table 1 - Guidance and Manufacturer's Declaration - Electromagnetic Emissions

Warning



- *Agilia pump and its accessories are intended to be used in the electromagnetic environments specified below.*
- *The customer or the user of Agilia pump should ensure that it is used in such environments.*

Emission Test	Compliance Obtained by the Device	Electromagnetic Environment - Guidance
RF emissions CISPR 11	Group 1	Agilia pump only uses RF energy for its internal operation. Its RF emissions are therefore very low and are not likely to cause any interference in nearby electronic equipment.
RF emissions CISPR 11	Class B	Agilia pump is suitable for use in all establishments other than domestic and those directly connected to the public low-voltage power supply network that supplies buildings used for domestic purposes.
Harmonic emissions IEC61000-3-2	Class A	
Voltage fluctuations Flicker emissions IEC 61000-3-3	N/A	
Conducted emissions 150 kHz - 108 Mhz CISPR25	Class 5	Agilia pump is suitable for use in automotive environments.
Radiated emissions 150 kHz - 2.5 Ghz CISPR25	Class 3	

23.4.2 Table 2 - Guidance and Manufacturer's Declaration - Electromagnetic Immunity

Warning



- *Agilia pump and its accessories are intended to be used in the electromagnetic environments specified below.*
- *The customer or the user of Agilia pump should ensure that it is used in such environments.*

Immunity Test	IEC 60601-1-2 ----- IEC 60601-2-24 and ANSI/AAMI ID26 Test Level	Compliance Level Obtained by the Device	Electromagnetic Environment - Guidance
Electrostatic Discharge (ESD) IEC 61000-4-2	± 6 kV contact ± 8 kV air ----- ± 8 kV contact ± 15 kV air	± 8 kV contact ± 15 kV air	Floor coverings made from wood, tiles and concrete, with relative humidity level at least 30 %, make it possible to guarantee the necessary level of conformity. If it is not possible to guarantee this environment, additional precautions must be taken, such as: use of anti-static equipment, preliminary user discharge and the wearing of antistatic clothing.
Electrical fast Transient / burst IEC 61000-4-4	± 2 kV for power supply lines ± 1 kV for input output lines	± 2 kV for power supply lines ± 1 kV for input output lines	AC power quality should be that of a typical commercial or healthcare facility environment.
Surge IEC 61000-4-5	± 1 kV differential mode ± 2 kV common mode	± 1 kV differential mode ± 2 kV common mode	AC power quality should be that of a typical commercial or healthcare facility environment.
Voltage dips, short interruptions and voltage variations on power supply input lines IEC 61000-4-11	< 5% Ut (> 95% dip in Ut) for 0.5 cycles	< 5% Ut (> 95% dip in Ut) for 0.5 cycles	AC power quality should be that of a typical commercial or healthcare facility environment.
	40% Ut (60% dip in Ut) for 5 cycles	40% Ut (60% dip in Ut) for 5 cycles	
	70% Ut (30% dip in Ut) for 25 cycles	70% Ut (30% dip in Ut) for 25 cycles	For short and long interruptions (< than battery life) of AC power, the internal battery provides continuity of service.
	< 5% Ut (> 95% dip in Ut) for 5 s	< 5% Ut (> 95% dip in Ut) for 5 s	

Immunity Test	IEC 60601-1-2 ----- IEC 60601-2-24 and ANSI/AAMI ID26 Test Level	Compliance Level Obtained by the Device	Electromagnetic Environment - Guidance
Power frequency (50/60 Hz) magnetic field IEC 61000-4-8	3 A/m ----- 400 A/m	400 A/m	If necessary, the power of the magnetic field should be measured in the intended installation location to ensure that it is lower than compliance level. If the measured field in the location where Agilia pump is used exceeds the applicable magnetic field compliance level above, observe Agilia pump to verify that it is operating normally. If you notice abnormal performance, additional measures may be necessary, such as reorienting or relocating Agilia pump, or installing magnetic shielding.

Note: "Ut" is the AC Power voltage prior to applying the test level.

23.4.3 Table 4 - Guidance and Manufacturer's Declaration - Electromagnetic Immunity

Warning



- *Agilia pump and its accessories are intended to be used in the electromagnetic environments specified below.*
- *The customer or the user of Agilia pump should ensure that it is used in such environments.*

Immunity Test	IEC 60601-1-2 ----- IEC 60601-2-24 and ANSI/AAMI ID26 Test Level	Compliance Level Obtained by the Device	Electromagnetic Environment - Guidance
Conducted RF IEC 61000-4-6	3 Vrms 150 kHz to 80 MHz ----- Not applicable	3 Vrms	Portable and mobile RF communication equipment should be used no closer to any part of Agilia pump (including cables), than the recommended separation distance calculated from the transmitter frequency equation. Recommended separation distance: $D = 0.35 \sqrt{P}$, for a frequency of 150 kHz to 80 MHz

Immunity Test	IEC 60601-1-2 ----- IEC 60601-2-24 and ANSI/AAMI ID26 Test Level	Compliance Level Obtained by the Device	Electromagnetic Environment - Guidance
Radiated RF IEC 61000-4-3	3 V/m 80 MHz to 2.5 GHz ----- 10 V/m 80 MHz to 2.5 GHz	10 V/m	<p>$D = 0.35 \sqrt{P}$, for a frequency of 80 MHz to 800 MHz $D = 0.7 \sqrt{P}$, for a frequency of 800 MHz to 2.5 GHz</p> <p>P is the maximum output power rating of the transmitter in Watts (W) according to the transmitter manufacturer, and D is the recommended separation distance in meters (m).</p> <p>Field strengths from fixed RF transmitters, as determined by an electromagnetic site survey (a), should be less than compliance level (b).</p> <p>Interference may occur in the vicinity of equipment marked with the following symbol: </p>

Notes:

- At 80 MHz and 800 MHz, the highest frequency range applies.
- These guidelines may not apply to all situations. Absorption and reflection from structures, objects and people may affect the electromagnetic propagation.
- (a) Field strengths from fixed transmitters, such as base stations for radio (cell / cordless) telephones and land mobile radios, amateur radio, AM and FM radio broadcasts and TV broadcast cannot be predicted theoretically with accuracy. To assess the electromagnetic environment due to the fixed RF transmitters, an electromagnetic site survey should be considered. If the measured field strength in the location where Agilia pump is used exceeds the applicable RF compliance level above, Agilia pump should be observed to verify normal operation. If abnormal performance is observed, additional measures may be necessary, such as reorienting or relocating Agilia pump, or installing magnetic shielding.
- (b) Over the frequency range of 150 kHz to 80 MHz, field strengths should be less than 10 V/m.

23.4.4 Table 6 - Recommended Separation Distances Between Portable and Mobile RF Communication Equipment and Agilia pump

Information

- *Agilia pump and its accessories are intended for use in electromagnetic environments in which radiated RF disturbances are controlled.*
- *Users of Agilia pump may prevent electromagnetic interference by maintaining a minimum distance between portable and mobile RF communication equipment (transmitters) and Agilia pump as recommended below, and according to the maximum output power of the communication equipment (transmitters).*
- *The device should not be used next to other equipment. If adjacent use is necessary, observe the device to verify that it operates normally in the configuration in which it will be used (pump with a AC power cord, an RS232 cable).*



Rated Maximum Output Power of Transmitter (W)	Separation Distance According to Transmitter Frequency in Meters (m)		
	150 kHz to 80 MHz $D = 0.35 \sqrt{P}$	80 MHz to 800 MHz $D = 0.35 \sqrt{P}$	800 MHz to 2.5 GHz $D = 0.7 \sqrt{P}$
0.01	0.04	0.04	0.07
0.1	0.11	0.11	0.22
1	0.3	0.3	0.7
10	1.1	1.1	2.2
100	3.5	3.5	7

For transmitters rated at a maximum output power not listed above, the recommended separation distance D in meters (m) can be estimated using the equation applicable to the transmitter frequency, where P is the maximum output power rating of the transmitter in watts (W) as designated by the transmitter manufacturer.

Information

- *At 80 MHz and 800 MHz, the separation distance for the higher frequency range applies.*
- *These guidelines may not apply in all situations. Electromagnetic propagation is affected by absorption and reflection from structures, objects and people.*



23.4.5 EMC test deviations and supplementary tests

To ensure compatibility with the new EMC standard IEC / EN 60601-1-2 Ed4 and special environments, specific, additional or deviating tests are listed below with respect to the basic tests, in accordance to manufacturer risk analysis.

Immunity test	IEC 60601-1-2 IEC 60601-2-24 Test level	Compliance level obtained by the device	Electromagnetic environment – guidance
Discharge (ESD) IEC 61000-4-2	± 8 kV contact ± 15 kV air	± 8 kV contact ± 15 kV air	Wooden, tiled or concrete flooring, with a relative humidity level at least 30%, makes it possible to guarantee the level of necessary conformity. If it is not possible to guarantee this environment, the additional precautions must be taken, such as: use of anti-static material, preliminary user discharge and wearing anti-static clothing.
Radiated RF - IEC 61000-4-3	10 V/m, 80 MHz à 2,7 GHz	10 V/m, 80 MHz à 2,7 GHz	Portable and mobile RF communications equipment should be used no closer to any part of the Agilia pump, including cables, than the recommended separation distance calculated from the equation applicable to the frequency and power of transmitter For standard communication services and equipment, the specific frequencies were tested for a minimum approach distance of 30 cm and 10 cm (see below)
Near field radiated RF IEC 61000-4-3 test method	385 MHz, PM 18Hz, 27 V/m 450 Mhz, 1 KHz, 28 V/m 710 MHz, PM 217 Hz, 9 V/m 745 MHz, PM 217 Hz, 9 V/m 780 MHz, PM 217 Hz, 9 V/m 810 MHz, PM 18 Hz, 28 V/m 870 MHz, PM 18 Hz, 28 V/m 930 MHz, PM217 18 Hz, 28V/m 1720 MHz, PM 217 Hz, 28 V/m 1845 MHz, PM 217 Hz, 28 V/m 1970 MHz, PM 217 Hz, 28 V/m 2450 MHz, PM 217 Hz, 28 V/m 5240 MHz, PM 217 Hz, 9 V/m 5500 MHz, PM 217 Hz, 9 V/m 5785 MHz, PM 217 Hz, 9 V/m	Not tested Not tested Not tested Not tested Not tested Not tested Not tested Not tested Not tested 2450 MHz, PM 217 Hz, 28 V/m 5240 MHz, PM 217 Hz, 9 V/m 5500 MHz, PM 217 Hz, 9 V/m 5785 MHz, PM 217 Hz, 9 V/m	For minimal distance approach 30 cm (12 inches) "Not tested" frequencies are replaced by IEC 61000-4-39 test method and reduced minimal distance approach (see below) Portable and mobile RF communications equipment should be used no closer to any part of the Agilia pump, including cables, than the recommended minimal separation distance (30 cm) for these frequencies
Near field radiated RF - special test IEC 61000-4-39 test method	450 MHz, PM 217 Hz, 28 V/m 710 MHz, PM 217 Hz, 28 V/m 787 MHz, PM 217 Hz, 28 V/m 810 MHz, PM 217 Hz, 44 V/m 830 MHz, PM 217 Hz, 44 V/m 870 MHz, PM 217 Hz, 44 V/m 1750 MHz, PM 217 Hz, 28 V/m 1875 MHz, PM 217 Hz, 28 V/m 1970 MHz, PM 217 Hz, 28 V/m 2560 MHz, PM 217 Hz, 28 V/m 2655 MHz, PM 217 Hz, 28 V/m	450 MHz, PM 217 Hz, 28 V/m 710 MHz, PM 217 Hz, 28 V/m 787 MHz, PM 217 Hz, 28 V/m 810 MHz, PM 217 Hz, 44 V/m 830 MHz, PM 217 Hz, 44 V/m 870 MHz, PM 217 Hz, 44 V/m 1750 MHz, PM 217 Hz, 28 V/m 1875 MHz, PM 217 Hz, 28 V/m 1970 MHz, PM 217 Hz, 28 V/m 2560 MHz, PM 217 Hz, 28 V/m 2655 MHz, PM 217 Hz, 28 V/m	For minimal distance approach 10 cm 250 mW average power for 28 V/m test level 600 mW average power for 44 V/m test level Portable and mobile RF communications equipment should be used no closer to any part of the Agilia pump, including cables, than the recommended minimal separation distance (10 cm) for these frequencies

Immunity test	IEC 60601-1-2 IEC 60601-2-24 Test level	Compliance level obtained by the device	Electromagnetic environment – guidance
Electrical Fast transient / Burst IEC 61000-4-4	± 2 kV for power supply lines ± 1 kV for input output lines 100 KHz repetition	± 2 kV for power supply lines ± 1 kV for input output lines 100 KHz repetition	Electricity power quality should be that of a typical domestic, commercial or hospital environment
Surge IEC 61000-4-5	± 1 kV differential mode ± 2 kV common mode	± 1 kV differential mode Does not apply	Electricity power quality should be that of a typical domestic, commercial or hospital environment. For very exposed establishments or buildings with the lightning, a protection must be installed on electricity power. Class II product and no earth connexion.
Conducted RF IEC 61000-4-6	3 Vrms 150 KHz to 80 MHz And 6 Vrms in the ISM and amateur radio bands	3 Vrms 150 KHz to 80 MHz And 6 Vrms in the ISM and amateur radio bands	Portable and mobile RF communications equipment should be used no closer to any part of the Agilia pump including cables, than the recommended separation distance calculated from the equation applicable to the frequency and power of transmitter (see table 6)
Power frequency (50 / 60 Hz) magnetic field IEC 61000-4-8	400 A / m	400 A / m	If necessary, the power magnetic field should be measured in the intended installation location to make sure it is lower than the compliance level. If the measured field in the location where the Agilia pump is used exceeds the applicable magnetic field compliance level above, the Agilia pump should be observed to verify normal operation. If abnormal performance is observed, additional measures may be necessary, such as reorienting or relocating the Agilia pump, or installing magnetic shielding.
Voltage dips, short interruptions and voltage variations on power supply input lines IEC 61000-4-11	0 % Ut (100% dip in Ut) for 0,5 cycle at 0°, 45°, 90°, 135°,180°, 225°, 270°,and 315° 0% Ut (100% dip in Ut) for 1 cycle 70% Ut (30% dip in Ut) for 25 cycles at 50 Hz for 30 cycles at 60 Hz at 0°	0 % Ut (100% dip in Ut) for 0,5 cycle at 0°, 45°, 90°, 135°,180°, 225°, 270°,and 315° 0% Ut (100% dip in Ut) for 1 cycle 70% Ut (30% dip in Ut) for 25 cycles at 50 Hz for 30 cycles at 60 Hz at 0°	Electricity power quality should be that of a typical domestic, commercial or hospital environment. For short and long interruptions (< than battery autonomy) of electricity power supply, the internal battery provides the continuity of service. For very long (> than battery autonomy) interruptions of electricity power supply, the Agilia pump must be powered from an external Uninterruptible Power Supply (UPS). Note: Ut is the a/c mains voltage prior to application of the test level.

24 Servicing

24.1 Information on Device Servicing

If the device must be sent for servicing, proceed as follows:

1. Contact **Fresenius Kabi** to have packaging shipped to your facility.
2. Clean and disinfect the device.
3. Pack the device in the provided packaging.
4. Ship the device to **Fresenius Kabi**.

Information



- **Fresenius Kabi** is not liable for loss or damage to the device during transport.
- For more information on servicing, contact your **Fresenius Kabi** sales representative.

24.2 Maintenance Requirements

Warning



Perform preventive maintenance at least once every 3 years. This includes replacing the battery.

To ensure the device continues to operate normally, follow the instructions below:

- Preventive maintenance should be performed by trained and qualified technical personnel in compliance with the technical manual and procedures. Only authorized service personnel should attempt to repair the device.
- The qualified personnel must be informed if the device is dropped or if any malfunctions occur. In this case, do not use the device and contact your biomedical department or **Fresenius Kabi**.
- Failure to comply with these maintenance procedures could damage the device and lead to a functional failure. Internal inspection of the device requires compliance with special procedures to avoid damage to the device.
- When replacing components, only use spare parts from **Fresenius Kabi**.

The life cycle of the pump is 10 years provided that the maintenance is properly performed as described above.

Information



*If the device needs upgrading, **Fresenius Kabi** or its representative will provide relevant instructions. It is the healthcare facility's responsibility to follow **Fresenius Kabi**'s instructions.*

24.3 Quality Control

Upon request by the healthcare facility, a quality control check can be performed on the device every 12 months.

A regular quality control check (not included in the guarantee) consists of various inspection operations listed in the technical manual.

Information



- *These control checks must be performed by trained technical personnel, and are not covered by any contract or agreement provided by **Fresenius Kabi**.*
- *For more information, refer to the technical manual, or contact your **Fresenius Kabi** sales representative.*

25 Glossary of Terms

Term	Description
A	Amperes
AC	Alternating Current
Ah	Ampere-hours
AIDC	Automatic Identification and Data Capture
AM	Amplitude Modulation
A/m	Amperes per meter
BPSK	Binary Phase Shift Keying
BSA	Body Surface Area
cal	Calorie
CCK	Complementary Code Keying
CDC	Centers for Disease Control
CISPR	Special International Committee on Radio Interference
CT Scan	Computed Tomography
dBA	Decibels
dBm	Decibels-Milliwatts
DC	Direct Current
DECT	Digital Enhanced Cordless Telecommunications
DEHP	Di(2-ethylhexyl) phthalate
DERS	Dose Error Reduction Software
DHCP	Dynamic Host Configuration Protocol
DTBI	Dose to Be Infused
DI	Dose Infused
DPS	Dynamic Pressure System
DSSS	Direct Sequence Spread Spectrum
DUR	Duration

Term	Description
ECG	Electrocardiogram
ECMO	ExtraCorporeal Membrane Oxygenation
EEG	Electroencephalogram
EMC	Electromagnetic compatibility
ErXX	Error message
ESD	Electrostatic Discharge
FCC	Federal Communications Commission
FM	Frequency Modulation
ft	Feet
GPL	General Public License
GTIN	Global Trade Item Number
H/W/D	Height / Width / Depth
HF	High Frequency
hPa	Hectopascals
HTTP	HyperText Transfer Protocol
Hz	Hertz
IC	Industry Canada
IEC	International Electrotechnical Commission
IEEE	Institute of Electrical and Electronics Engineers
IFU	Instructions for Use
in	Inches
IT	Information Technology
IV	Intravenous
kg	Kilograms
KVO	Keep Vein Open
lb(s)	Pound(s)
LED	Light Emitting Diode

Term	Description
mA	Milliamperes
mEq	Milliequivalents
mL/h	Milliliters per hour
mmHg	Millimeters of Mercury
mmol	Millimole
MOS	Metal Oxyde Semiconductor
MRI	Magnetic Resonance Imaging
mW/sr	Milliwatts per steradian
N/A	Not Applicable
NMR	Nuclear Magnetic Resonance
OCS	Occlusivity Check System
OFDM	Orthogonal Frequency Division Multiplexing
OR	Operating Room
PC	Personal Computer
PSI	Pounds per Square Inch
PSK	Phase Shift Keying
QAM	Quadrature Amplitude Modulation
QPSK	Quadrature Phase Shift Keying
REF	Product reference / part number
RF	Radio Frequency
RFID	Radio Frequency IDentification
RS232	Serial interface connector
SN	Serial Number
SELV	Safety Extra Low Voltage
SIR	Asynchronous Serial Infrared
TCP	Transmission Control Protocol
UDI	Unique Device Identifier

Term	Description
USB	Universal Serial Bus
Ut	Test specification level
V	Volts
VA	Volt-Amperes
VDC	Volts Direct Current
VI	Volume Infused
Vrms	Root Mean Square Voltage
VTBI	Volume to Be Infused
V/m	Volts per meter
W	Watts
WPA	Wi-Fi Protected Access

Appendix: Factory Configuration

	Feature	Availability
Menus	Profile	✘
	Pressure	✓
	Keypad lock status	✓
	Battery life	✓
	Volume infused / Dose infused	✓
	Pause	✓
	Programmed bolus	✓
	Patient	✘
	Day/Night mode	✓
	Volume/Time Dose/Time	✓
	Volume Limit	✘
	Alarm volume	✓
	Volume-Dose history	✘
	View flow rate history	✓
	View pressure history	✓
	Syringe	✘
	View event log	✓
	Date / Time	✘
	Maintenance	✘
	Library information	✓
Clinical information	✘	
Data Set	✓	

	Feature	Availability
Infusion Modes	Simple Rate	✓
	Volume/Time Dose / Time	✓
	Volume Limit	✓
Infusion Features	Direct Bolus	✓
	Programmed Bolus	✓
	Loading Dose	✘
	KVO	✓
	Prime Set	✘
	Dynamic Pressure System (DPS)	✓

✓ = Activated with factory configuration (Basic Profile).

✘ = Not activated with factory configuration. Can be activated in the pump options or with Agilia Vigilant Drug¹Lib software. Otherwise can be activated on request.

Index

A

- Agilia Connect Infusion System 14
- Agilia USB Cable 93
- Alarm
 - Adjust Volume 79
 - List 97
 - Priority 18, 96
 - Sound Level 126
- Arrow Keys 18

B

- Battery
 - Characteristics 124
 - Charge Level 33, 72
 - Full Charge Time 32
 - Operating Mode 123
- Bolus 53
 - Direct 54
 - Programmed 55, 75

C

- Cables 92
- Cleaning 118
- Clinical Information Message 88
- Contraindications 12

D

- Data Communication 92
- Data Set 25
 - Display Information 89
 - Upload 20, 94
- Date / Time 85, 91
- Day Mode 76
- Dimensions and Weight 127
- Disinfecting 118
- Dose 24, 41, 51
- Dose/Time 59, 78
- Drug 24
 - Concentration Selection 41
 - Select 40
- Drug Library 23
 - Display Information 87
- Drug X (mL/h) 24

E

- Electromagnetic Guidance 137
- Empty Syringe 57
- Environment 13
- Essential Features 110

- Event Log 84

F

- Factory Configuration 153
- First Use 32
- Flow Rate 24, 41, 50

G

- Glossary 149
- Graphics
 - Flow Rate History 81
 - Pressure History 82

H

- Hard Limit 24

I

- Infusion
 - Change Infusion Rate 52
 - End 57
 - Monitor 50
 - Pause 74
 - Program 41
 - Start 49
 - Stop 52
 - View History 80
- Infusion Modes 25, 59
- Infusion Status 19
- Installation 26
- Intended Use 9

K

- Keypad
 - Description 17
 - Lock / Unlock 70
 - Unlock Code 91
- KVO 60, 61

L

- Language Selection 91
- Loading Dose
 - Pause 47
 - Program 46
 - Select 45
 - Stop 47

M

Maintenance 147
 Display Information 86
 Reminder Message 33
 Requirements 147

Menu

 Customization 91
 List 65

Monitoring

 Dose 51
 Flow Rate (ml/h) 50

N

Navigation Buttons 20
Near End of Infusion Alert 57
Night Mode 76

O

Options 90

P

Packaging 21
Patient Characteristics 11, 113
 Change 75
 Select 44
Power Cord 124
Power Supply 18, 124
Powering Off 58
Powering On 32
Pre-programming 64
Pressure
 DPS 69
 Management 113
 Modify Limit 67
 Operating Range 13
Priming
 Manual Prime 104
 Prime With Pump 62
Profile 22
 Basic Profile 22
 Custom Profile 23
 Display Information 66
 Select 37

Q

Quick-Start 63

R

Recycling 135

Release Notes 156
Rotating Pole Clamp 27

S

Screen

 Contrast 91
 Display and Symbols 19
Selection Keys 18
Servicing 147
Simple Rate 59
Soft Limit 24
 Override 47
Software Version 156
Sound Levels 126
Stop function 52
Storage 108
Symbol Descriptions 2
Syringe 103
 Change 106
 Display Information 83
 Install 32
 List 103
 Remove 106
 Replacement Interval 106
 Select 39

T

Table of Contents 3
Temperature
 Operating Range 13
Titration 52
Training 11
Troubleshooting 133
Trumpet Curves 127

U

Units 116
User Test 95

V

Volume Infused 73
Volume Limit 60, 78
Volume/Time 59, 78
VTBI 59, 111

W

Warranty 136
Wi-Fi 19, 91, 93, 130

Release Notes

Date	Software Version	Description
January 2017	2.2	Creation

This document may contain inaccuracies or typographical errors.

Modifications may thus be made, and included in later editions.

Due to the evolution of standards, and of legal texts and materials, the characteristics indicated in the text and images of this document are applicable only to the device with which it is included.

The screenshots in this document are for illustrative purposes only. Screen contents may vary based on individual configurations and minor software modifications; therefore, some screenshots may appear slightly different from what you see on the product.

This document may not be reproduced in whole or in part without the written consent of **Fresenius Kabi**. Vigilant® and Agilia® are registered trademarks in the name of **Fresenius Kabi** in selected countries.

Made in France

Revision date: **January 2017**



Fresenius Kabi AG
61346 Bad Homburg
Germany



Fresenius Vial S.A.S
Le Grand Chemin
38590 Brézins
France

www.fresenius-kabi.com



First CE Mark: Agilia SP MC WiFi: December 2015
Agilia SP MC: November 2016

Local Contacts for Servicing

Write your contacts here:

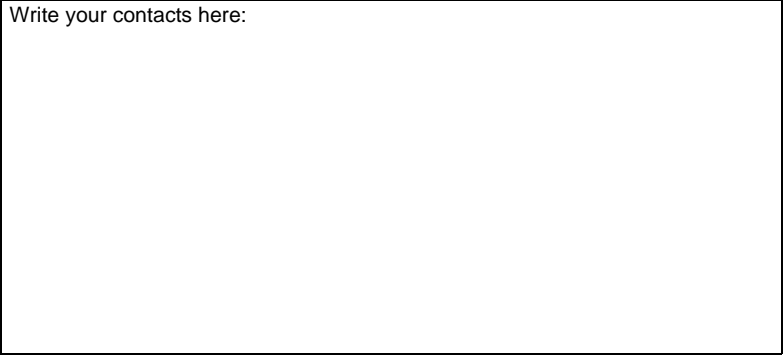



**FRESENIUS
KABI**

caring for life

11502-2_ifu_agilia_sp_mc_eng